

CHAPTER 600 PAVEMENT STRUCTURAL SECTION

Topic 601 - General Considerations

Index 601.1 - Introduction

Pavement structural section design is determined by a combination of pavement, base, and subbase layers that are best suited to specific project conditions. In California, this combination of materials placed in layers above the top of the basement soil (the grading plane) is most often referred to as the "structural section." The AASHTO "Guide for Design of Pavement Structures" refers to it as the "pavement structure." "Pavement," the uppermost surface layer of the structural section that carries the traffic, is normally either portland cement concrete or asphalt concrete. The asphalt concrete pavement layer may include a layer of open graded asphalt concrete.

It is impossible to reduce the design of the structural section into exact mathematical formulas based entirely on theory because of the many variables involved. The design guidelines and standards included herein are based on a wide range of information including: theory; test track studies; experimental sections; research on materials, methods, and equipment; and, perhaps most important of all, the observation of structural section performance throughout the state and the nation. The final structural section design must be based on a thorough investigation of specific project conditions including materials, environmental conditions, projected traffic, cost effectiveness, and on the performance of other project structural sections under similar conditions in the same area.

601.2 Structural Section Design Objectives

Structural sections are to be designed using the standards and guidance described herein. This will assure adequate strength, consistency, and durability to carry the predicted traffic loads for the design life

of each project. Pavement type selection may be dictated by specific project conditions such as:

- Predicted uneven foundation settlements
- Maintaining or changing grade profile
- Highly expansive basement soils
- Groundwater
- Availability of materials
- Type of pavement on existing adjacent lanes or facilities
- Corridor continuity
- Traffic considerations
- Maintenance considerations
- Climate impacts
- Stage construction
- Size of project
- Other factors

If the pavement type is not dictated by any of these factors, alternative designs (flexible and rigid) must be considered for each project. The final decision on pavement type should be the most economical design based on "life-cycle costs" which include initial cost, maintenance cost, traffic delay cost, and rehabilitation cost. Topic 605 discusses pavement type selection and economic analysis in more detail. The various basic structural elements of the roadway are shown diagrammatically in Figure 601.2.

601.3 Roles and Responsibilities

The roles and responsibilities listed below apply only to the design of the pavement structural section.

- (1) *Project Engineer (PE)* - The registered civil engineer in responsible charge of appropriate project development documents (i.e., PSR, Project Report, etc.) and project design; is responsible for project technical decisions, design quality, and estimates; obtains input and recommendations from the District Materials Engineer and other subject matter experts (as appropriate) regarding pavement structural section design and details; selects pavement

Figure 601.2
Basic Structural Elements of the Roadway^{1,2}

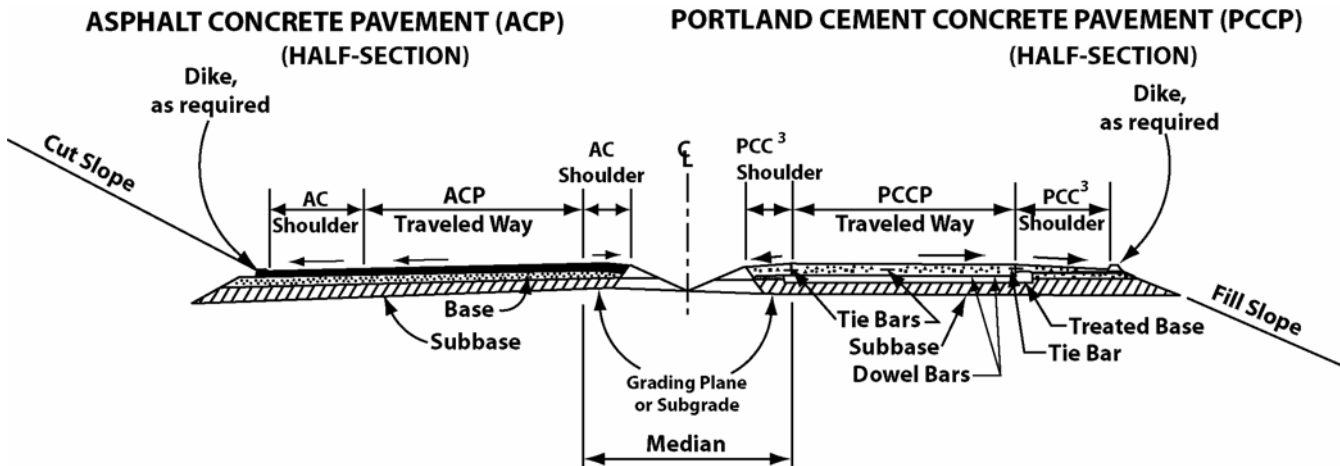

DIVIDED HIGHWAYS

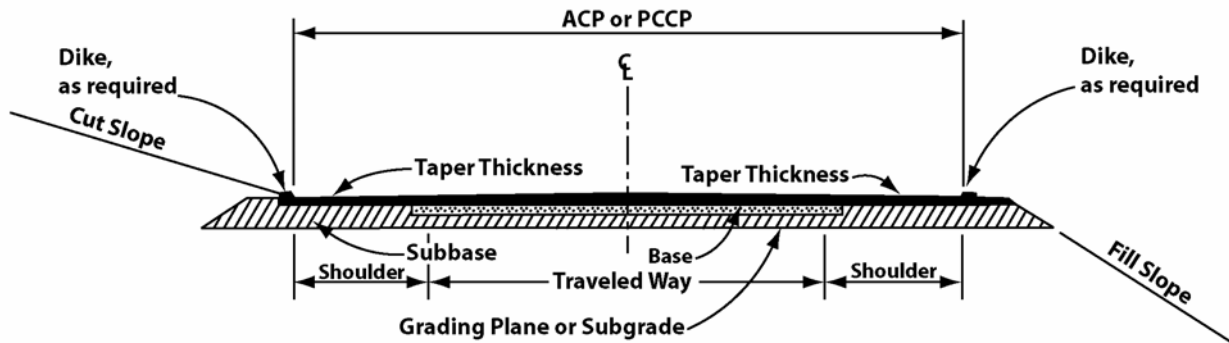

UNDIVIDED HIGHWAYS

Notes:

1. These illustrations are only to show nomenclature and are not to be used for geometric cross section details. For these, see Chapter 300.
2. Structural section drainage elements, both on divided and undivided highways, are illustrated and discussed under Topic 606.
3. AC shoulders may be used when justified per Index 603.4.

structural section, final rehabilitation strategy, and pavement design details; and clearly conveys this information on the project plans and specifications for a Contractor to bid and build the project.

- (2) *District Materials Engineer (DME)* - Responsible for Materials information, when requested, for each project; prepares the Materials Report for each project; provides recommendations to and in continuous consultation with the Project Engineer and Resident Engineer throughout planning, design, and construction; coordinates Materials information with Caltrans functional units, Material Engineering and Testing Services (METS), Headquarters functional units, local agencies, industry, and consultants.
- (3) *Pavement Program Steering Committee (PPSC)* - Provides leadership and commitment to assure safe, effective, and environmentally sensitive highway pavement structural sections that improve mobility across California. Responsible for assuring structural section pavement initiatives, policies, and standards that reflect departmental goals; provides clear direction and priorities on pavement structural section initiatives; implements pavement structural section policies, standards, and specifications. Members include Headquarters Division Chiefs and some District Directors.
- (4) *Pavement Standards Team (PST)* - Multifunctional group consisting of METS, Design, Construction, Maintenance, Research and Innovation, Office Engineer, and selected District Materials Engineer representatives; provides structural section related policies, procedures, and practices to ensure quality of structural section features regarding design, construction, maintenance, and rehabilitation; develops and maintains structural section standards, specifications, and procedures; provides recommendations to the PPSC; approves nonstandard specifications. The chairperson of this team is the single focal point of contact for pavement related issues.

- (5) *Materials Engineering and Testing Services (METS)* - A subdivision of the Division of Engineering Services, METS is responsible for conducting standard and specialized laboratory and field testing, inspections, giving expert advice on all phases of transportation engineering involving materials and manufactured products; provides technical expertise for the development of statewide standards, guidelines, and procedure manuals; works closely with the District Materials Engineers and Resident Engineers to investigate ongoing field problems and/or disputes.
- (6) *Division of Design (DOD)* - Responsible for statewide consistency in the project design process. The Office of State Pavement Design (OSPD) is part of the DOD. OSPD is responsible for communicating and maintaining pavement structural section design standards, policies, procedures, and practices that are used statewide.

601.4 Research and Experimentation

Research and experimentation are continuing in order to provide improved design methods and standards, which take advantage of new technology, materials, and methods. Submittal of new ideas by Headquarters and District staff, especially those involved in the design, construction, maintenance, and materials engineering of the structural section, is encouraged. Suggested research should be sent to the Division of Research and Innovation in Sacramento. The Pavement Standards Team must approve experimental construction features before completing the final design phase of a project (refer to Index 601.5(2)). District Maintenance should also be engaged in the discussion involving experimental construction features.

Suggestions for research studies and changes in design standards may also be submitted to the Pavement Standards Team (PST).

601.5 Record Keeping

The following are instructions for the retention of pavement structural section design information:

(1) *Selection of Pavement Type.* One complete copy of the documentation for the type of pavement approved by the District Director should be retained in permanent District Project History files as well as subsequent updates of construction changes to the structural section. The documentation must contain the design period, R-values of the basement soil, the R-value(s) selected for the structural section(s) design, and the lane traffic index (TI) for each design. In addition, it must include the data required by the instructions set forth under Topic 605 for selection of pavement type, including a life-cycle cost analysis.

A life-cycle cost analysis should be completed for pavement type selection on projects with $TI \geq 10$ unless the pavement type is dictated by specific project conditions as discussed in Index 601.2.

(2) *“Special” Designs.* “Special” designs must be fully justified and submitted to DOD Office of Pavement Design for approval. “Special” designs are defined as those designs which involve products or strategies that meet any of the following:

- Reduce the structural sections to less than what is determined by the standards and procedures of this manual and the Flexible Rehabilitation Manual.
- Utilize experimental products or procedures (such as mechanistic-empirical design method) not covered in the design tables or methods found in this manual and accompanying technical guidance.

Submittals may be sent either electronically or with hard copies. Hard copy submittals must be in duplicate. Include the proposed structural section design(s) and a location strip map (project title sheet is acceptable). The letter of transmittal should include the design period (including both the construction year and design year), the R-value(s) of the basement soil(s), the R-value(s) selected for the structural section(s) design, the lane TI for

each structural section, and justification for the “special” design(s). DOD will act as the Headquarters focal point to obtain concurrence, as required, of PST representatives prior to DOD granting approval of the “special” designs.

(3) *Proprietary Items.* The use of new materials, methods, or products may involve specifying a patented or brand name method, material, or product. The use of proprietary items is discouraged in the interest of promoting competitive bidding.

When proprietary items are needed and beneficial to the State, their use must be approved by the District Director or by the Deputy District Director of Design (if such approval authority has been specifically delegated by the District Director). The Deputy Division Chief of Engineering Services, Structure Design, approves the use of proprietary materials on structures and other design elements under their jurisdiction. The use of proprietary items requires approval (i.e., Public Interest Finding) by the Federal Highway Administration (FHWA) Division Office if the project is on the National Highway System (NHS), including the Interstate Highway System. Caltrans’ policy and guidelines on the use of proprietary items are covered in the Office Engineer’s Ready to List and Construction Contract Award Guide (RTL Guide) under “Trade Names.” This policy is based on Public Contract Code, Division 2, Chapter 3, Article 5, Paragraph 3400. It is also consistent with FHWA regulatory requirements. The use of proprietary materials, methods, or products will not be approved unless:

- (a) There is no other known material of equal or better quality that will perform the same function, or
- (b) There are overwhelming reasons for using the material or product in the public’s interest, which may or may not include savings, or
- (c) It is essential for synchronization with existing highway or adjoining facilities, or

- (d) Such use is on an experimental basis, with a clearly written plan for “follow-up and evaluation.”

In addition to the RTL Guide requirements, the FHWA requires that the following information be documented when a proprietary item is specified in the design of a pavement structural section:

- (a) If it must be constructed on or immediately adjacent to an existing facility: year the existing facility was constructed and the original structural section details,
- (b) Traffic data (Average Daily Traffic (ADT), Peak Hour Flow, Annual Average Daily Truck Traffic (AADTT), TI),
- (c) Accident data,
- (d) Construction cost of the project,
- (e) When FHWA oversight is required per the stewardship agreement, name of FHWA representative who reviewed the proposed project, and
- (f) Tentative advertising schedule.

If the proprietary item is to be used experimentally and there is Federal participation, the request for FHWA approval must be submitted to the Chief, Office of Resolution of Necessity, Encroachment Exceptions, and Resource Conservation in the Division of Design. The request must include a Construction Evaluated Work Plan (CEWP), which indicates specific functional managers, and units, which have been assigned responsibility for objective follow-up, evaluation, and documentation of the effectiveness of the proprietary item. See Section 3-404 Scope of Work (“Construction-Evaluated Research”) of the Construction Manual for further details on the work plan and the approval procedure.

Technical assistance is available from the Pavement Standards Team to assist with designs that utilize new materials, methods, and products. When no standard specification or standard special provision exists for the proprietary item, the Pavement Standards

Team must review and concur with the special provision. For further information see the Specifications section of the Pavement web site <http://www.dot.ca.gov/hq/oppd/pavement/specs.htm>

- (4) *Subsequent Revisions.* Any subsequent changes in structural sections must be documented and processed in accordance with the appropriate instructions stated above and with proper reference to the original design.

601.6 Other Resources

The following resources provide additional information on pavement design. Much of this information can be found on the Pavement website at <http://www.dot.ca.gov/hq/oppd/pavement/index.htm>.

- (1) *Standard Plans.* Generally, these are collections of commonly used design details intended to provide consistency for Contractors and designers in defining the scope of work for projects and assist in the biddability of the project contract plans.
- (2) *Standard Specifications and Standard Special Provisions.* The Standard Specifications provide material descriptions, materials quality and workmanship requirements, contract administration terms and definitions, and measurement and payment clauses for items entering the project. The Standard Special Provisions are additional specification standards used to modify the Standard Specifications for those items entering the project and include descriptions, quality requirements, and measurement and payment.
- (3) *Pavement Technical Guidance.* Pavement Technical Guidance is a collection of supplemental guidance and manuals regarding pavement design which is intended to assist designers, materials engineers, specialists, construction oversight personnel, and maintenance workers in making informed decisions on pavement structural section issues. Information includes, but is not limited to, aids for assistance in decision making, rigid and flexible pavement structural section rehabilitation strategies, and guidelines for the use of various products and materials. These Technical Guidance documents may be

accessed on the Pavement website at: <http://www.dot.ca.gov/hq/oppd/pavement/guidance.htm>.

- (4) *The AASHTO "Guide for Design of Pavement Structures."* The AASHTO "Guide for Design of Pavement Structures," although not adopted by Caltrans, is a comprehensive reference guide that provides background that is helpful to those involved in design of pavement structural sections. This reference is on file in the Division of Design and a copy should be available in each District. Design procedures included in the AASHTO Guide are used by FHWA to check the adequacy of the specific structural sections adopted for Caltrans projects, as well as the procedures and standards included in Chapter 600 of this manual. The AASHTO Guide was developed by a team of nationally recognized pavement structural section design experts with detailed input from several states, including California.
- (5) *Supplemental District Guidance.* Some Districts have developed additional structural section guidance to address local issues. Such guidance only supplements and does not replace the Headquarters guidance found in this manual, the Pavement Technical Guidance, the standard plans, specifications, and special provisions. Supplemental District Guidance can be obtained by contacting the District Materials Engineer.

Topic 602 – Pavement Service Life and Traffic Data

602.1 Introduction

This topic discusses the factors to be considered and procedures to be followed in developing an estimate of traffic loading for design of the "pavement structure" or the structural section for specific projects.

Pavement structural sections are designed to carry the projected truck traffic expected to occur during the pavement service life. This truck traffic is the primary factor affecting pavement life. Passenger cars, pickups, and two-axle trucks are considered to be negligible.

Truck traffic information that is required for structural section design includes axle loads, axle configurations, and number of applications. A mixed truck traffic stream of different axle loads and axle configurations are converted to an equivalent number of 80 kN axle loads for the design life. Finally, this sum is converted to a Traffic Index or TI (Index 602.4), which is used to select a standard portland cement concrete pavement structural section (Topic 603) or design an asphalt concrete pavement structural section (Topic 604).

Because of the complexity involved in developing travel forecasts, Districts typically have established a unit specifically responsible for providing travel forecasting information. These units are responsible for developing traffic projections (including trucks and equivalent single axle loads) for the planning and designing of State highways. The District Office Chief responsible for travel forecasting should notify the Headquarters Office of Travel Forecasting and Analysis (OTFA) in the Division of Transportation Systems Information if there is a significant difference between the traffic used to determine ESAL's and the traffic forecast by the regional agency in urban areas. The notification should include the reasons for the deviation so that OTFA may offer recommendations or provide consultation relative to the chosen methodology.

602.2 Pavement Service Life

Pavement Service Life is the period of time that a newly constructed or rehabilitated pavement structural section is designed to perform before reaching its terminal serviceability or a condition that requires major rehabilitation or reconstruction; this is also referred to as the performance period. The selected pavement service life varies depending on the characteristics of the highway facility, the objective of the project, and the severity of traffic. The strategy or structural section selected for any project needs to provide the minimum pavement service life that meets the objective of the project as described below.

On resurfacing projects, the entire paved shoulder and traveled way shall be resurfaced. Not only does this help provide a smoother finished surface, it also benefits bicyclists and pedestrians when they are allowed to use the shoulder.

- (1) *Capital Preventive Maintenance (CAP-M) Projects.* **The pavement service life for CAP-M projects shall be a minimum of 5 years to meet FHWA funding criteria.** CAP-M guidelines are available by contacting Headquarters Maintenance, Pavement Maintenance Managers. Additional information and guidance may be found in the Project Development Procedures Manual (PDPM) Appendix H at the following website address: <http://www.dot.ca.gov/hq/oppd/pdpm/pdpm.htm>.
- (2) *Pavement Rehabilitation Projects.* **The minimum pavement service life for rehabilitation projects shall be at least 10 years.** Longer service lives of 15, 20, and even 30 years may be more appropriate when the cost of the additional work is only incrementally higher. A Life-cycle Cost Analysis (LCCA) can be an effective tool in determining the most cost effective service life. LCCA is discussed further in Index 605.3. A pavement service life longer than 10 years needs concurrence from the District Maintenance Engineer and the Headquarters Rehabilitation Program Manager. For corridors with at least a current Annual Average Daily Traffic (AADT) of 150 000 or Annual Average Daily Truck Traffic (AADTT) of 15 000, it is recommended that a minimum pavement service life of 30-40 years be used.
- (3) *New Construction and Reconstruction.* **The minimum pavement service life must be no less than the project design period (see Index 103.2) or 20 years, whichever is greater. Where a project will meet either of the following criteria, the minimum pavement service life shall be 40 years:**
- The projected AADT 20 years after completion of construction equals or exceeds 150 000.
 - The projected AADTT will equal or exceed 15 000 trucks 20 years after the completion of construction.

The development of a 30 or 40 year TI may be difficult. District Transportation Planning and/or Traffic Operations should be involved

in determining a realistic and appropriate TI. Refer to Index 62.7 for the definition of new construction and reconstruction.

- (4) *Widening.* Additional consideration is needed when determining the service life for pavement widening. Factors to consider include the remaining service life of the existing pavement, planned future projects, and future corridor plans for any additional lane widening and shoulders. **At a minimum, the pavement service life for widenings shall match the adjacent roadway's pavement service life, but not be less than the pavement service life required for new construction and reconstruction as noted in Index 602.2(3).** See Index 604.4 for shoulder design considerations if future roadway widening is a potential. An economic analysis is recommended to assist in project decisions.

To minimize traffic handling, it may be advantageous to combine a widening project with needed rehabilitation. For example, grinding the adjoining PCC lane next to the proposed widening can improve constructability and provide a smoother pavement surface for the widening. The Project Development Procedures Manual Chapter 8, Section 7 provides additional guidance on widening adjacent to existing facilities.

- (5) *Temporary Pavements and Detours.* During construction, lane detours should be designed to accommodate the anticipated traffic during construction. This period of time may be several years and it is important to determine the traffic index based on the truck traffic the pavement will actually experience.

602.3 Truck Traffic Projection

- (1) *Mainline Traffic.* Considerable judgment is required to develop realistic traffic volume projections.

Truck traffic volume and loading projections on State Highways can come from weigh-in-motion (WIM) stations, the Vehicle Classification Program, and the Truck Weight Studies. Traffic and truck volume projections

and loading can be obtained from District Traffic or Planning.

The Division of Design uses information from the Truck Weight Study to develop 80 kilonewton (kN) Equivalent Single Axle Load (ESAL) constants that represent the estimated total accumulated ESAL, for each of the four axle configurations, during the design service life. The current 10-, 20-, and 40-year ESAL Constants are shown in Table 602.3A.

**Table 602.3A
ESAL Constants**

Vehicle Type	10-year Constants	20-year Constants	40-year + Constants
2-axle trucks	690	1380	2760
3-axle trucks	1840	3680	7360
4-axle trucks	2940	5880	11 760
5-axle trucks or more	6890	13 780	27 560

The ESAL constants are used as multipliers of the expanded AADTT to determine the total design period ESAL's and in turn the TI. The ESAL's and the resulting TI are the same magnitude for both AC and PCC pavement design alternatives.

The distribution of truck traffic by lanes must be considered in the structural section design for all multilane facilities. Truck traffic is generally lightest in the median lanes and heaviest in the outside lanes. Because of the uncertainties and the variability of lane distribution of trucks, lane distribution factors have been established for design purposes as shown in Table 602.3B.

**Table 602.3B
Lane Distribution Factors
for Multilane Roads**

Number of Lanes in One Direction	Factors to be Applied to Expanded Average Daily Trucks			
	Lane 1	Lane 2	Lane 3	Lane 4
One	1.0	-	-	-
Two	1.0	1.0	-	-
Three	0.2	0.8	0.8	-
Four	0.2	0.2	0.8	0.8

NOTES:

1. Lane 1 is next to the centerline or median.
2. For more than four lanes in one direction, use a factor of 0.8 for the outer two lanes and any auxiliary/collector lanes and a factor of 0.2 for all other lanes.

Finally, an expansion factor is developed for each axle classification. In its simplest form, the expansion is a straight-line projection of the AADTT data. When using the straight-line projection the data is projected to find the AADTT at the middle of the design period, thus representing the average AADTT for each axle classification for the design period. The expanded AADTT, for each axle classification, is multiplied by the appropriate lane distribution factor (fraction of the total AADTT) to arrive at the expanded AADTT for the lane. The lane AADTT is multiplied by the design period ESAL constant for each corresponding axle classification. Finally, the summation of these totals equals the total one-way ESAL's for the lane, which is converted into the TI for the lane (See Table 602.4B Example).

When other than a straight-line projection of available truck traffic data is used for design purposes, the procedure to be followed in developing traffic projections will vary. It will be dependent on a coordinated effort of the District's Planning and Traffic Divisions working closely with the Regional Agencies.

- (2) *Shoulder Traffic.* See Index 603.4 and 604.4 for PCC and AC shoulder design respectively.
- (3) *Ramp Traffic.* Estimating future truck traffic on ramps is more difficult than on through traffic lanes. The relative effect of the commercial and industrial development in an area is much greater on ramp truck traffic than it is on mainline truck traffic.

As an alternative to estimating and projecting an AADTT to determine the ramp TI, ramps may be classified and designed as follows:

- (a) *Light Traffic Ramps* - Ramps serving undeveloped and residential areas with light to no truck traffic should be designed for a TI of 8.0.
- (b) *Medium Traffic Ramps* - Ramps in metropolitan areas, business districts, or where increased truck traffic is quite likely to develop because of anticipated commercial development within the design period should be designed for a TI of 10.0.
- (c) *Heavy Traffic Ramps* - Ramps that serve weigh stations, industrial areas, truck terminals, and/or maritime shipping facilities should be designed for a TI of 12.0 for a pavement service life of 20 years or less and 14.0 for a pavement service life of greater than 20 years.

When ramps are widened to handle truck offtracking, the full structural section, based on the ramp TI, should be extended to the inner edge of the required widening, see 504.3(1)(b).

- (4) *Auxiliary Lane Traffic.* Because of structural section drainage considerations, the auxiliary lane structural section should perpetuate any drainage layer of the existing adjacent lane.
- (5) *Freeway-to-Freeway Connectors.* TI's for connectors should be determined the same way as for mainline traffic.

602.4 Traffic Index

The Traffic Index or TI is a measure of the number of ESAL's expected in the design lane over the design period. The TI does not vary linearly with the ESAL's but rather according to the following

exponential formula and as illustrated in Table 602.4A.

$$TI = 9.0 \times (ESAL/10^6)^{0.119}$$

Where:

TI = Traffic Index

ESAL = Total number of 80 kN Equivalent Single Axle Loads

Table 602.4B illustrates the determination of the TI for outside and median lanes of an 8-lane freeway. The expanded AADTT and the TI's shown in Table 602.4B are not intended to be used in the design for a specific project.

Topic 603 - Portland Cement Concrete Pavement Structural Section Design

603.1 Introduction

Portland cement concrete (PCC) pavement, or rigid pavement, should be considered as a potential alternative for all state highway facilities. PCC pavement should always be considered on Interstate and other interregional freeways. Standard structural sections are included herein for a range from very high to relatively low volumes of traffic. Truck traffic and soil conditions are the principal factors considered in selecting the structural section, however life-cycle economics and other pertinent or overriding factors may ultimately determine the pavement type to be used on any given project.

603.2 Design Procedure for Rigid Pavement

(1) Tie Bars and Dowel Bars.

New or reconstructed PCC pavements shall be doweled and tied except as noted below:

- Interior lane replacements (lanes not adjacent to a shoulder) should be undoweled if all adjacent lanes are undoweled.
- PCC shoulders being placed or reconstructed next to an undoweled PCC lane can be undoweled.
- PCC pavement should not be tied to adjacent PCC pavement with tie bars when the spacing of transverse joints of adjacent slabs is not the same.

Table 602.4A
Conversion of ESAL to Traffic Index

ESAL	TI*	ESAL	TI*	ESAL	TI*
48	3.0	164 000	7.5	9 490 000	12.0
194	3.5	288 000	8.0	13 500 000	12.5
646	4.0	487 000	8.5	18 900 000	13.0
1850	4.5	798 000	9.0	26 100 000	13.5
4710	5.0	1 270 000	9.5	35 600 000	14.0
10 900	5.5	1 980 000	10.0	48 100 000	14.5
23 500	6.0	3 020 000	10.5	64 300 000	15.0
47 300	6.5	4 500 000	11.0	84 700 000	15.5
89 800	7.0	6 600 000	11.5	112 000 000	
164 000		9 490 000			

*NOTE:

The determination of the TI closer than 0.5 is not justified. No interpolations should be made.

Table 602.4B
Example Determination of the 20 Year Traffic Index
for an 8-lane Freeway

(1) Vehicle Type	(2) ESAL 20 Year Constants	Outside Lanes		Median Lanes	
		(3) Expanded Annual Average Daily Truck Traffic	(4) Total 20 Year ESAL (Col.2 x Col.3)	(5) Expanded Annual Average Daily Truck Traffic	(6) Total 20 Year ESAL (Col.2 x Col.5)
2-axle trucks	1380	935	1 290 300	235	324 300
3-axle trucks	3680	550	2 024 000	140	515 200
4-axle trucks	5880	225	1 323 000	55	323 400
5-axle or more	13 780	1025	14 124 500	255	3 513 900
Totals	----	----	18 761 800	----	4 676 800
Traffic Index (TI) for 20 Year Design, From Table 602.4A = 12.5				11.0	

NOTE: Table 602.4B is an example only and should not be used for a specific design.

- No more than 15 m width of PCC should be tied together with tie bars to preclude random cracks from occurring due to the pavement acting as one large PCC slab.

For slab replacements, the placement of dowel bars and tie bars should be determined on a project by project basis based on proposed service life, construction work windows, existence of dowel bars and tie bars in adjacent slabs, condition of adjacent slabs, and other pertinent factors. Further information on slab replacement design, see “Slab Replacement Guides” and companion documents on the Pavement website <http://www.dot.ca.gov/hq/oppd/pavement/guidance.htm>.

Dowel bars are smooth round bars that act as a load transfer device across a pavement joint. Tie bars are deformed bars or connectors that are used to hold the faces of abutting PCC slabs in contact. PCC shoulders used with PCC pavement are to be tied to the adjacent lane with tie bars, see Figure 603.2. Further details regarding dowel bars and tie bars can be found in the Standard Plans and Pavement Technical Guidance on the Pavement website.

(2) *Structural Section Thickness.*

Standard structural section thicknesses shown in Table 603.2 should be used in the design for new, widening, and reconstruction projects. Structural section element thicknesses vary with Traffic Index (TI) and R-value of the basement soil material. Procedures for developing the TI are described in Topic 602. The R-Value for the basement soil to be used is contained in the project Materials Report or available from the District Materials Engineer. With an expansive basement soil (Plasticity Index > 12) and/or basement soil R-value < 10, an asphalt concrete, or flexible pavement, structural section should be specified. If based on engineering analysis, the R-value of the basement soil can be raised above 10 by treatment, to a minimum depth of 200 mm, with an approved stabilizing agent such as lime, cement, asphalt, or fly ash, PCC pavement can be specified.

The final selection of which of the five bases, as shown in Table 603.2, should be used on a given project depends on specific factors relative to the available materials, terrain, environmental conditions, and past performance of PCC pavement under similar project or area conditions. When the TI is greater than 10, only lean concrete base or asphalt concrete base is allowed, except on widening projects where existing pavement structural sections having treated permeable base, the treated permeable base should be perpetuated along the same plane. Questions on selection of base material for rehabilitation projects may be directed to the Office of Pavement Rehabilitation in METS. Questions concerning structural section features for new construction and reconstruction projects may be directed to the Division of Design. Consultation with the District Materials Engineer should be an ongoing process for the project. The Office of Rigid Pavement Materials and Structural Concrete is also available to provide forensic studies and project specific consultation.

(3) *Drainage.*

Structural sections should be designed to promote free drainage whenever possible. Alternative designs are provided, as shown in Figure 606.2. Incorporation of a treated permeable base daylighting to the edge of embankment may be considered; otherwise, an edge drain collector and outlet system may provide positive drainage of the structural section. The climatic region of the project site should be a factor in selection of a drainable or dense base layer under the PCC pavement. A dense non-erodible base (lean concrete base or asphalt concrete base) may also be considered with or without an edge drain collector and outlet system as discussed in Topic 606.

When placing PCC over a lean concrete base, it is important to avoid bonding between the two layers. Bonding can cause cracks and joints in the lean concrete base to reflect through the PCC, which will lead to premature cracking failure. Several methods are available for preventing bonding including application of

**Table 603.2
PCC Pavement Structural Section Thickness Guidelines (mm)⁴**

TI	Basement Soil R-value 10-40					
	PCC ¹ Pavement	Base ³ (LCB, ACB)	Aggregate Subbase (AS)	Treated Permeable Base (ATPB, CTPB)	Aggregate Base (AB)	Aggregate Subbase (AS)
8 or less	205	105	120	105	105	105
8.5-10	215	105	150	105	105	105
10.5-12	230	120	185	--	--	--
12.5-13.5	270 ²	150	215	--	--	--
14+	300 ²	150	215	--	--	--
TI	Basement Soil R-value > 40					
	PCC ¹ Pavement	Base ³ (LCB, ACB)	Aggregate Subbase (AS)	Treated Permeable Base (ATPB, CTPB)	Aggregate Base (AB)	Aggregate Subbase (AS)
8 or less	205	105	--	105	105	--
8.5-10	215	120	--	105	120	--
10.5-12	230	120	--	--	--	--
12.5-13.5	270 ²	150	--	--	--	--
14+	300 ²	150	--	--	--	--

NOTES :

1. Additional thickness should be considered where chains are used for winter weather driving. Consult District Materials Engineer for recommendations.
2. Includes 10 mm of sacrificial thickness for future grinding.
3. In desert environment, where large temperature differentials occur, use ACB or, for LCB, place a minimum 30 mm AC between the LCB and PCC pavement layers.
4. The thicknesses shown in this table are only applicable for PCC pavement that includes either tied PCC shoulders or widened slab (see Index 603.4) and whose adjacent lanes are PCC pavement.

Legend

LCB = Lean Concrete Base	PCC = Portland Cement Concrete
ACB = Asphalt Concrete Base	CTPB = Cement Treated Permeable Base
ATPB = Asphalt Treated Permeable Base	AS = Aggregate Subbase
AB = Aggregate Base	

**Figure 603.2
Portland Cement Concrete Pavement Details**

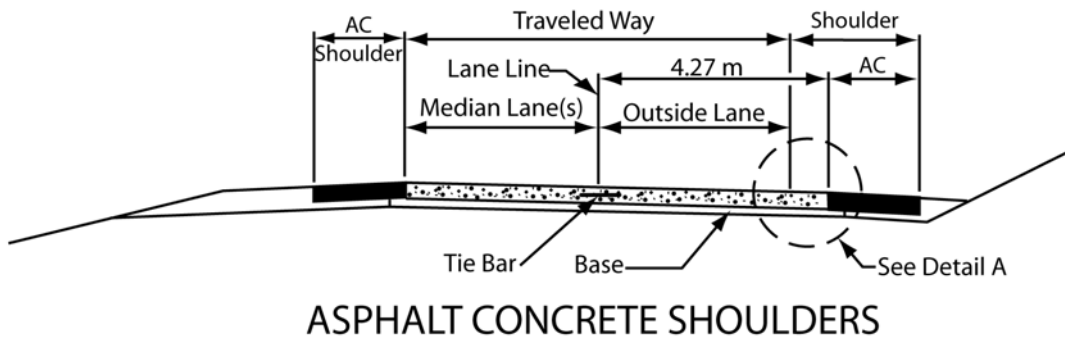
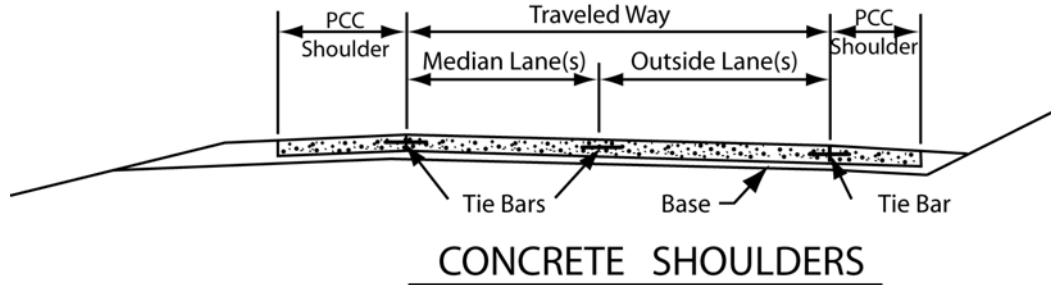

NOTE: These illustrations are only to show nomenclature and are not to be used for geometric cross section details.

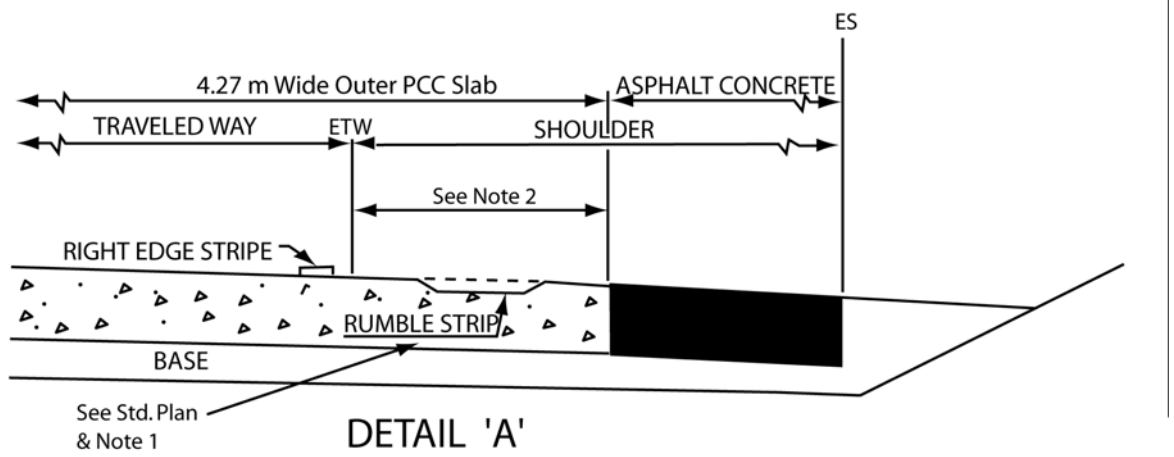

- NOTE: 1. Use of Rumble Strips is determined in consultation with District Traffic Operations.
2. 670 mm for 3.6 meter lane.
610 mm for 3.66 meter lane.

wax curing compound, slurry seals, or placing a 30 mm interlayer of AC. Application rates may be found in the Standard Specifications. For specific project recommendations on how to prevent bonding between PCC and lean concrete base, consult the District Materials Engineer.

Alternative combinations are diagramed in Table 603.2. Details of structural section drainage systems are provided in Topic 606 and the Standard Plans.

603.3 Structural Section Geometry

On projects with three or more lanes in one direction, the PCC pavement thickness should be constant for the median and outside lanes. When PCC shoulders are specified, a hinge point may be required at the median edge of the traveled way to minimize drainage across the pavement.

603.4 Shoulders

It is recommended that the shoulders be constructed of the same material as the mainline pavement in order to facilitate construction, improve pavement performance, and reduce maintenance cost. However, shoulders adjacent to PCC traffic lanes can be either PCC or AC with the following conditions:

- (a) **PCC shoulders shall be used for:**
- **PCC pavements constructed in mountainous areas that experience chain control (above 1300 m elevation)**
 - **Paved buffers between PCC High Occupancy Vehicle (HOV) lanes and PCC mixed flow lanes**
 - **PCC ramps to and from truck inspection stations**
- (b) **When AC shoulders are used, a widened concrete slab (4.27 m) shall be used in the outside lane, HOV lane(s), and truck bypass lanes (see Figure 603.2).** A rumble strip or a raised pavement marking is recommended next to the pavement edge line of widened concrete slabs to discourage trucks from driving on the outside 0.6 meters of the slab. The use of

rumble strips or raised markings requires approval from District Traffic Operations.

These conditions apply to all PCC paving projects including new construction, reconstruction, widening, adjacent lane replacements, and shoulder replacements. Typically existing AC shoulders next to PCC pavement are not replaced for rehabilitation projects that involve only grinding, dowel bar retrofits, and intermittent slab replacements unless the AC shoulder needs to be rehabilitated or replaced as part of the project.

Tied PCC shoulders or widened slabs increase the service life of PCC pavement by reducing edge stresses from trucks, buses, and other vehicles. PCC shoulders have the added benefit of reducing future maintenance costs and worker exposure.

The structural section selected must meet the pavement service life standards in Index 602.2. In selecting whether to construct PCC or AC shoulders the following factors should be considered:

- (a) Life-cycle cost of the shoulder
- (b) Construction cost of the shoulder
- (c) Ability and safety of maintenance crews to maintain the shoulder. In confined areas, such as in front of retaining walls or narrow shoulders, and on high volume roadways (AADT > 150,000) consideration should be given to providing a shoulder design that requires the least amount of maintenance, even if it is more expensive to construct.
- (d) Future plans to widen the facility or convert the shoulder to a traffic lane
- (e) Width of shoulder. When shoulder widths are less than 1.5 meters, tied PCC shoulders are preferable to a widened concrete slab and narrow AC shoulder (≤ 0.9 m).

The structural section for the PCC shoulder should match the structural section of the adjacent traffic lane. Cross slopes should meet the requirements found in Index 302.2. If the future conversion of the shoulder to a traffic lane is anticipated within the pavement service life of the pavement, it is preferred that the shoulder width match the width of

the future lane. Special delineation of concrete shoulders may be required to deter the use of the shoulder as a traveled lane. District Traffic Operations should be consulted to determine the potential need for anything more than the standard edge stripe.

In those instances where AC shoulders are used with PCC pavement, the minimum AC thickness should be determined in accordance with Index 604.4

603.5 Freeway-to-Freeway Connectors and Ramps

PCC should be considered for all freeway-to-freeway connectors and ramps near major commercial or industrial areas, truck terminals, and truck weighing and inspection facilities ($TI \geq 12.0$) Heavy trucks cause deterioration by repeated heavy loading on the outside edge of pavement, at the corners, or at the midpoint of the slab leading to flexure of the pavement. Distress is compounded on AC ramps by the dissolving action of oil drippings combined with the braking of trucks. At a minimum, PCC pavement should be used as exit ramp termini on AC ramps where a significant volume of trucks is anticipated (see Index 603.6).

When the entire new ramp is concrete, it is recommended to utilize the same base and thickness as that to be used under the traveled way, especially when concrete shoulders are utilized. If the base is Treated Permeable Base (TPB) under the traveled way and shoulder, TPB should be utilized in the ramp area.

For ramp reconstruction, consider recycling the existing base and subbase layers. In some situations, underground water from landscape irrigation or other sources may tend to saturate the existing slow-draining layers, thereby creating the potential for pumping and pavement damage. In this case, the design should provide for removal of such water by a TPB drainage layer when reconstruction is required or by using other positive drainage features which minimize maintenance (e.g., daylighting the structural section layers).

603.6 Ramp Termini

PCC pavement is placed at ramp termini instead of AC to preclude pavement failure due to high

truck traffic ($TI > 12$), vehicular braking, turning movements, and oil dripping from vehicles. The length of PCC pavement to be placed at the termini will depend on the geometric alignment of the ramp, ramp grades, and the length of queues of stopped traffic. The PCC pavement should extend to the first set of signal loops on signalized intersections. A length of 45 m should be considered the minimum on unsignalized intersections. Special care should be taken to assure skid resistance in conformance with current standard specifications in the braking area, especially where oil drippage is concentrated.

The PCC pavement for the termini of AC exit ramps should meet the minimum TI requirements found in Table 603.2 except that the minimum TI used should be 12.5. Special attention should be given to base type selection to assure continuity and adequacy of drainage. District Traffic Operations should be consulted for recommendations regarding construction windows to mitigate traffic impacts.

603.7 Pavement Joints

In Portland cement concrete pavement, there are longitudinal and transverse construction joints, longitudinal and transverse weakened plane joints, and transverse pressure relief joints. Required spacing for transverse joints is found in the Standard Plans and Standard Specifications. Dowel bars are required in all transverse joints along with tie bars for longitudinal joints as discussed in Index 603.2(1). Joints are sawed into the new pavement. Additional PCC pavement joint and slab saw cutting requirements are available on the Pavement Technical Guidance page of the Pavement website <http://www.dot.ca.gov/hq/oppd/pavement/guidance.htm>, Standard Specifications, Standard Special Provisions, and the Standard Plans.

Joints should be sealed to prevent incompressible materials from filling the joints and causing the concrete to spall. Seals also limit the entry of water that could otherwise degrade the underlying structural section layers. Various products or systems for sealing joints are available or are being developed. Each one differs in cost and service life. The need to specify the sealing of joints should be discussed in the Materials Report or by contacting the District Materials Engineer. For additional

information on various joint seal products, consult the Pavement Technical Guidance on the Pavement website <http://www.dot.ca.gov/hq/oppd/pavement/guidance.htm>, Standard Specifications, Standard Special Provisions, Standard Plans, or contact your District Materials Engineer or METS Office of Rigid Pavement Materials and Structural Concrete.

603.8 PCC Pavement Maintenance and Rehabilitation

Pavement maintenance and rehabilitation is the use of a single or combination of several preventive or corrective strategies, which will provide the best overall solution to extend the pavement service life for a predetermined number of years. The choice of strategies depends primarily on the pavement condition, traffic impacts, life-cycle cost considerations, and apparent rate of deterioration. The Materials Report should discuss any historical problems observed in the performance of PCC pavement constructed with aggregates found near the proposed project and subjected to similar physical and environmental conditions. The use of rapid strength concrete in the replacement of concrete slabs should be given consideration to minimize traffic impacts and open the facility to traffic in a minimal amount of time. The rate of deterioration is based on experience, field observation, and a review of successive annual Pavement Condition Survey Reports provided by Caltrans Division of Maintenance. The selection of the appropriate strategy may be based upon constructability, cost, deflection testing (if load transfer is a concern), materials testing, ride quality, safety, visual inspection of pavement distress, and other factors based upon project needs.

Pavement Scoping Team reviews are scheduled and coordinated by the District, with final approval by the District Director. See the Project Development Procedures Manual for further procedures and details.

PCC pavement structural section rehabilitation strategies may be found on the Design Pavement website under Technical Guidance at: <http://www.dot.ca.gov/hq/oppd/pavement/guidance.htm>.

Topic 604 - Asphalt Concrete Pavement Structural Section Design

604.1 Introduction

Asphalt concrete (AC) pavement should be considered as a potential alternative for all state highway facilities since it adjusts readily to differential settlement that is likely to occur where the roadway is constructed on relatively flexible or variable quality basement soil. Asphalt concrete is readily repaired or recycled and should be considered when traffic impacts must be minimized.

Asphalt concrete structural sections may be constructed from new or recycled materials including rubberized asphalt concrete (RAC), cold or hot recycling, cold foam in-place recycling, and pulverization, to name a few. Additionally, different asphalt binders have been developed to address different climatic and environmental constraints. The Pavement website includes discussions of the various asphalt pavement types and their applicability. The site may be found at: <http://www.dot.ca.gov/hq/oppd/pavement/guidance.htm>.

604.2 Design Data Requirements and Sources

The data needed to design a structural section are R-value of the basement soil and the Traffic Index (TI) for the pavement service life. The R-value is a measure of the resistance to deformation of the basement soil under saturated soil conditions and wheel loading. The R-value method of design is based on two separate measurements:

- (1) The R-value determines the thickness of cover or structural section required to prevent plastic deformation of the soil under imposed wheel loads.
- (2) The expansion pressure test determines the thickness or weight of cover required to maintain the compaction of the soil.

Fine grained and sandy soils may exhibit high R-values (greater than 50) and on occasion, the R-value test may not provide sufficient thickness of cover. Local experience with these soils should

govern in assigning a design R-value. The determination of R-Value for basement soils is provided under California Test Method (CTM) 301. Further discussion may be found on the Division of Design's Pavement website under Technical Guidance located at the following link: <http://www.dot.ca.gov/hq/oppd/pavement/guidance.htm>.

The R-Values of materials to be used on a project are contained in the Materials Report. The R-Value of basement soils within a project may vary substantially but cost and constructability should be considered in specifying one R-value for the project.

Judgment based on experience should still be exercised to assure a reasonably "balanced design" which will avoid excessive costs resulting from over conservatism.

If the range of R-value is small or if most of the values are in a narrow range with some scattered higher values, the lowest R-value should be selected for the structural section design. The lowest R-value should not, however, necessarily govern the structural section design throughout the length of long projects. If there are a few exceptionally low R-values and they represent a relatively small volume of basement soil or they are concentrated in a small area, it may be possible to specify placing this material in the bottom of an embankment or in the slope area outside the structural section limits. Occasionally lime treatment of a short length may be cost effective.

The placement of geotextiles below the structural section will provide subgrade enhancement by bridging soft areas and providing a separation between soft pumpable subgrade fines and high quality subbase or base materials. Soft areas are defined as:

- Poor soils which are classified in the unified soil classification system (USCS) as sandy clay (SC), silty clay (CL), high plastic clay (CH), silt (ML), high plasticity or micaceous silt (MH), organic silt (OL), organic clay (OH), and peat & mulch (PT).
- Low undrained shear strength (equivalent to Caltrans R-value < 20).
- High water table, and high soil sensitivity.

Where changing geological formations and soil types are encountered along the length of a project, it may be cost-effective to design more than one structural section to accommodate major differences in R-value that extend over a considerable length. Care should be exercised, however, to avoid multiple variations in the structural section design that may actually result in increased construction costs that exceed potential materials cost savings.

Design of the flexible pavement structural section is based on a relationship between the "gravel equivalent" (GE) of the structural section materials, the Traffic Index (TI), and the R-value (R) of the underlying material. This relationship was developed by the Department through research and field experimentation and is represented by the following equation:

$$GE = 0.975 (TI)(100-R)$$

Gravel equivalency (GE) may be defined as the required gravel thickness needed to carry a load compared to a different material's ability to carry the same load. Gravel factor (G_f) is the relative strength of a material to gravel. Gravel factors for the various types of base materials are provided in Table 604.2. The relationship between the two is that the GE may be divided by the G_f to obtain the material's thickness as follows:

$$\text{Thickness (t)} = \frac{GE}{G_f}$$

Structural section safety factors are utilized to compensate for construction tolerances allowed by the contract specifications. For structural sections that include base and/or subbase, a safety factor of 60 mm is added to the GE requirement for the AC layer. Since the safety factor is not intended to increase the GE of the structural section, a compensating thickness is subtracted from the subbase layer (or base layer if there is no subbase). For structural sections that are full depth AC, a safety factor of 30 mm is added to the required GE of the AC and is not removed. When determining the appropriate safety factor to be added, ACB and ATPB should be considered as part of the AC layer.

Table 604.2
Gravel Factor and R-Values for Subbases and Bases

Type of Material	Abbreviation	Gravel Factor (G_f)	Design R-Value
Aggregate Subbase	AS-Class 1	1.0	60
	AS-Class 2	1.0	50
	AS-Class 3	1.0	40
	AS-Class 4	1.0	specify
	AS-Class 5	1.0	specify
Aggregate Base	AB-Class 2	1.1	78
	AB-Class 3	1.1 ²	specify
Asphalt Treated Permeable Base	ATPB	1.4	NA
Cement Treated Base	CTB-Class A	1.7	NA
	CTB-Class B	1.2	80
Cement Treated Permeable Base	CTPB	1.7	NA
Lean Concrete Base	LCB	1.9	NA
Lime Treated Subbase	LTS	0.9 + $\frac{UCS}{6.9}$	NA

Notes:

- For Asphalt Concrete Base (ACB), see Pavement Technical Guidance at:
<http://www.dot.ca.gov/hq/oppd/pavement/guidance.htm>
- Must conform to the quality requirements of AB-Class 2.

Legend:

NA = Not Applicable
UCS = Unconfined Compressive Strength in MPa

604.3 Structural Section Design Procedures for New and Reconstruction Projects

A computer program for flexible pavement structural section design is available from METS' Office of Pavement Rehabilitation or the District Materials Engineer. The use of this program is recommended because it automatically employs the rules of the flexible pavement design procedure and enables the designer to compare numerous combinations of materials in seeking the most economical structural section. Numerous examples of flexible structural section design solutions are available on the Division of Design's Pavement website located at: <http://www.dot.ca.gov/hq/oppd/pavement/guidance.htm>.

The procedures and rules governing flexible structural section design are:

- (1) The TI is determined to the nearest 0.5.
- (2) The following standard design equation is applied to calculate the gravel equivalent (GE) requirement of the entire structural section or each layer:

$$GE = 0.975(TI)(100-R)$$

where:

- GE = gravel equivalent in mm
- TI = traffic index (See Index 602.4)
- R = R-value of the basement material. This may also be the R-value of the material below the layer for which the GE is being calculated.

- (3) GE values for each type of material are found in Table 604.3 by layer thicknesses. The G_f of asphalt concrete increases for any given TI as follows:

$t \leq 150 \text{ mm:}$	$G_f = \frac{5.67}{(TI)^{1/2}}$
$t > 150 \text{ mm:}$	$G_f = (1.04) \frac{(t)^{1/3}}{(TI)^{1/2}}$

- (4) Design – The GE to be provided by each type of material in the structural section is

determined for each layer, starting with the AC and proceeding downward. The thickness of each material layer is calculated by dividing the GE by the appropriate gravel factor from Table 604.3. When selecting the design layer thickness, the value is rounded to the nearest 15 mm. A value midway between 15 mm increments is rounded to the next higher value.

The following design example illustrates the general methodology to be followed.

- (a) AC/Untreated Base/Aggregate Subbase:

AC Layer: Calculate the initial $GE_{(AC)}$ from standard design equation using the R-value of the aggregate base material (AB) and add the safety factor to get the required $GE_{(AC)}$. Refer to Table 604.3 and select the closest GE layer thickness. A GE value midway between two GE values should be rounded to the next higher value. Finally, determine the $GE_{(AC)}$ value from Table 604.3 that the design layer thickness provides or corresponds to.

Untreated Base Layer: Calculate the initial $GE_{(AC+AB)}$ from the standard design equation using the R-value of the subbase material and add the safety factor. From this, subtract the $GE_{(AC)}$ taken from Table 604.3 to get the required $GE_{(AB)}$ (i.e., $GE_{(AB)} = GE_{(AC+AB)} - GE_{(AC)}$). Refer to Table 604.3 and select the closest layer thickness. Determine the adjusted $GE_{(AB)}$ that the design layer thickness provides.

Untreated Subbase Layer: Calculate the $GE_{(total)}$ (without the safety factor) for the entire structural section using the standard design equation with the R-value of the basement material. Then subtract the $GE_{(AC+AB)}$ as taken from Table 604.3, provided by the AC layer and AB layer ($GE_{(AS)} = GE_{(total)} - GE_{(AC+AB)}$). Finally, refer to Table 604.3 and select the closest layer thickness. (In this way, the GE of the subbase is decreased by the amount of the safety factor.) This thickness is also the adjusted $GE_{(AS)}$ that the subbase provides since the G_f for the subbase is 1.0.

Finally, summarize the structural layer thicknesses and adjusted GE's to easily check that all the requirements are satisfied.

(b) Full Depth AC:

Full depth AC (FDAC) is asphalt concrete used for the entire structural section in lieu of base and subbase. Considerations regarding worker safety, short construction windows, the amount of area to be paved, or temporary repairs may make it desirable to reduce the total thickness of the structural section by placing full depth AC. FDAC also is less affected by moisture or frost, provides no moisture build up in the subgrade, provides no permeable layers to entrap water, and is a more uniform structural section. Use the standard design equation with the R-value of the basement material to calculate the initial GE for the entire structural section. Increase this by adding the safety factor (indicated in Index 604.2) to obtain the required GE of the AC. Then refer to Table 604.3, select the closest layer thickness for AC, and determine the adjusted GE that it provides. The GE of the safety factor is not removed in this design.

An asphalt concrete base (ACB) may be utilized for part of the full depth AC pavement since ACB is considered part of the pavement design. The dense graded AC surface layer should have a minimum thickness of 45 mm.

A treated permeable base (TPB) layer may be placed below full depth AC or within the AC layer on widening projects to perpetuate, or match, an existing treated permeable base layer for continuity of drainage. Reduce the GE of the AC by the amount of GE provided by the TPB. In no case should the initial GE of the AC layer over the TPB be less than 40% of the GE required over the subbase as calculated by the standard design equation. When there is no subbase, use 50 for the R-value for this calculation. In cases where a working table will be used, the GE of the working

table is subtracted from the GE of the AC as well. A working table is a minimum thickness of material, asphalt, base, or subbase, used to place construction equipment and achieve compaction requirements when compaction is difficult or impossible to meet.

- (5) Base and subbase materials, other than ATPB, should each have a minimum thickness of 105 mm. When the calculated thickness of base or subbase material is less than the desired 105 mm minimum thickness, either (a) increase the thickness to the minimum without changing the thickness of the overlying layers or (b) eliminate the layer and increase the thickness of the overlying layers to compensate for the reduction in GE.
- (6) When Lime Treated Subbase (LTS) is used as a subbase it is substituted for all, or part, of the required AS layer. The design thickness of the base and AC surfacing layers are determined as though AS is the planned subbase material. The LTS is then substituted for the AS.

Since AS has a G_f of 1.0, the actual thickness and the GE are equal. When LTS is substituted for the AS, the actual thickness is determined by dividing the GE by the appropriate G_f based on unconfined compressive strength. The gravel factor for LTS is calculated from the Unconfined Compressive Strength (UCS) of the treated soil measured in MPa using the formula:

$$G_f = 0.9 + \frac{UCS}{6.9}$$

Generally, the layer thickness of LTS should be limited, with 200 mm as the minimum and 600 mm as the maximum thickness. An asphalt concrete layer placed directly on the LTS should have a thickness of at least 75mm.

Because the lime treatment of the basement soil may be less expensive than the base material, the calculated base thickness can be reduced and the LTS thickness increased because of cost considerations. The base layer thickness is reduced by the corresponding gravel equivalency provided by the lime treated basement soil or subbase.

**Table 604.3
Gravel Equivalents of Structural Layers (mm)**

	ASPHALT CONCRETE (DGAC)											BASE AND SUBBASE					
	Traffic Index (TI)																
	5 & below	5.5 6.0	6.5 7.0	7.5 8.0	8.5 9.0	9.5 10.0	10.5 11.0	11.5 12.0	12.5 13.0	13.5 14.0	14.5 & up	ACB; LCB	CTPB; CTB (Cl. A)	CTB (Cl. B)	ATPB	AB	AS
Actual Thickness of Layer (mm)	Gravel Factor (G _f)																
	G _f varies with TI ⁴											G _f constant					
	2.54	2.32	2.14	2.01	1.89	1.79	1.71	1.64	1.57	1.52	1.46	1.9	1.7	1.4	1.2	1.1	1.0
30	76	70	64	60	57	54	51	49	47	46	44	--	--	--	--	--	--
45	114	104	96	90	85	81	77	74	71	68	66	--	--	--	--	--	--
60	152	139	128	121	113	107	103	98	94	91	88	--	--	--	--	--	--
75	191	174	161	151	142	134	128	123	118	114	110	--	--	105 ²	--	--	--
90	229	209	193	181	170	161	154	148	141	137	131	--	--	126	--	--	--
105	267	244	225	211	198	188	180	172	165	160	153	200	180 ²	147	126	116	105
120	305	278	257	241	227	215	205	197	188	182	175	228	204	168	144	132	120
135	343	313	289	271	255	242	231	221	212	205	197	257	230	189	162	149	135
150	381	348	321	302	284	269	257	246	236	228	219	285	255	210	180	165	150
165	421	392	362	338	318	301	287	275	264	254	247	314	281	231	198	182	165
180	473	441	407	380	357	338	322	308	296	285	278	342	306	252	216	198	180
195	526	490	453	422	397	377	359	343	329	317	309	371	332	273	234	215	195
210	--	541	500	466	439	416	396	379	363	350	341	399	357	--	252	231	210
225	--	593	548	511	481	456	434	415	399	384	374	428	383	--	270	248	225
240	--	647	597	557	524	497	473	452	434	418	407	456	408	--	288	264	240
255	--	--	647	604	568	538	513	491	471	453	442	485	434	--	306	281	255
270	--	--	698	652	613	581	553	529	508	489	477	513	459	--	324	297	270
285	--	--	--	701	659	625	595	569	546	526	512	542	485	--	342	314	285
300	--	--	--	750	706	669	637	609	585	563	548	570	510	--	360	330	300
315	--	--	--	801	753	714	680	650	624	601	585	599	536	--	378	347	315
330	--	--	--	--	802	759	723	692	664	639	623	--	--	--	--	--	330
345	--	--	--	--	851	806	767	734	705	679	661	--	--	--	--	--	345
360	--	--	--	--	900	853	812	777	746	718	699	--	--	--	--	--	360
375	--	--	--	--	--	901	858	820	787	758	738	--	--	--	--	--	375
390	--	--	--	--	--	949	904	864	830	799	778	--	--	--	--	--	390
405	--	--	--	--	--	998	950	909	873	840	818	--	--	--	--	--	--
420	--	--	--	--	--	--	997	954	916	882	859	--	--	--	--	--	--
435	--	--	--	--	--	--	1045	1000	960	924	900	--	--	--	--	--	--
450	--	--	--	--	--	--	1094	1046	1004	967	942	--	--	--	--	--	--
465	--	--	--	--	--	--	--	1093	1049	1010	984	--	--	--	--	--	--
480	--	--	--	--	--	--	--	1140	1094	1054	1026	--	--	--	--	--	--
495	--	--	--	--	--	--	--	1188	1140	1098	1069	--	--	--	--	--	--
510	--	--	--	--	--	--	--	--	1187	1143	1113	--	--	--	--	--	--
525	--	--	--	--	--	--	--	--	1233	1188	1156	--	--	--	--	--	--
540	--	--	--	--	--	--	--	--	1280	1233	1201	--	--	--	--	--	--
555	--	--	--	--	--	--	--	--	--	1279	1245	--	--	--	--	--	--
570	--	--	--	--	--	--	--	--	--	1325	1290	--	--	--	--	--	--
585	--	--	--	--	--	--	--	--	--	1372	1336	--	--	--	--	--	--
600	--	--	--	--	--	--	--	--	--	--	1382	--	--	--	--	--	--

Notes:

- Standard layer thicknesses of 75 mm and 105 mm have been adopted respectively for ATPB and CTPB. These in turn correspond respectively to GEs of 105 mm and 180 mm. A thicker TPB drainage layer may be considered only under a unique combination of conditions.
- DGAC G_f also increases as the thickness increases, if the thickness is greater than 150mm - See Index 604.3(3).
- Rubberized layer thicknesses may be found in the Flexible Pavement Rehabilitation Manual, Table 3 and 4.
- Open Graded Asphalt Concrete is a surface wearing course and provides no structural value.

A subbase layer or even a base layer may be omitted if the R-value of the basement soil is relatively high. Lime treatment (or stabilization) may in some cases increase the R-value of a soil so that the subbase or even the base layer may be omitted.

- (7) The thickness of other structural section layers (other than AC, ATPB, and CTPB) determined by the procedures described herein may be adjusted to accommodate construction practice and to minimize cost provided the minimum GE and construction requirements are satisfied.
- (8) Alternate Designs. The design thickness determined by the procedures provided in Index 604.3(4) are not intended to prohibit other combinations and thickness of materials. Adjustments to the thickness of the various materials (other than AC, ATPB, and CTPB) may be made to accommodate construction restrictions or practices, and minimize costs, provided the minimum GE requirements, including safety factors, of the basement soil and each layer in the structural section are satisfied.

At times, experimental designs and/or alternative materials are proposed. These should be designed, constructed, and evaluated in cooperation with METS and the District Materials Engineer. In addition, designs with a pavement service life greater than 20 years are to be submitted to the Division of Design, Office of Pavement Design for review. Refer to Index 601.5(2) for further discussion.

Alternative design examples are provided in the Design Pavement website found at: <http://www.dot.ca.gov/hq/oppd/pavement/guidance.htm>

604.4 Shoulder Structural Section Design

The structural section design of median and outside shoulders is based on the same method described for the traveled way in Index 604.3.

(1) *Traffic Index (TI)*.

It is recommended that the shoulder structural section match that of the adjacent traffic lane except that the thickness of the base or AC

pavement may vary to account for the different cross slope between the shoulder and traffic lane. At a minimum the design for an AC shoulder is based on no less than 2% of the projected ESAL's in the adjacent lane; however, a TI less than 5.0 should not be used.

In an area where there are sustained steep grades (over 4%) without a truck climbing lane, the potential for slow moving trucks to encroach on the shoulder should be investigated. If said encroachment results in the ESAL's exceeding 2%, the shoulder structural section should be designed to accommodate the larger ESAL value.

(2) *Grading Plane*.

Normally, there is no break in the grading plane under the pavement shoulder contact joint. The shoulder structural section can be designed with or without an aggregate subbase (AS) layer, depending on the comparative initial cost of aggregate base (AB) versus AS.

The total GE of the shoulder section is usually more than required due to the thickness of AB and/or AS.

(3) *Future Conversion to Lane*.

On new facilities, if the future conversion of the shoulder to a traffic lane is within the pavement service life, the shoulder structural section should be equal to that of the adjacent traveled way.

If a decision has been made to convert an existing shoulder to a portion of a traffic lane, a deflection study must be made to determine the structural adequacy of the in-place material. The condition of the existing shoulder must also be evaluated for undulating grade, rolled-up AC at the PCC joint, surface cracking, raveling, brittleness, oxidation, etc.

The converted facility must provide a roadway that is structurally adequate for the proposed pavement service life. This is to eliminate or minimize the likelihood of excessive maintenance or rehabilitation being required in a relatively short period of time because of inadequate structural strength and deterioration of the existing AC.

(4) Medians.

In addition to the information in Index 305.5(2), when a median is 4.2 m wide or less on multi-lane undivided cross sections, the median structural section should be equivalent to the adjacent lanes.

604.5 Ramp Structural Section Design

Structural section design for AC ramps is based on the same method used for the traveled way, as described in Index 604.3. Refer to Index 602.3(3) for determination of design traffic for ramps.

(1) Structural Section Drainage. Provisions for positive, rapid drainage of the structural section is very important, as stated in Topic 606, on ramps as well as main lanes. However, including drainage systems in ramp structural sections can sometimes create drainage problems such as accumulation of water in the subgrade of descending ramps approaching local street intersections in flat terrain. Situations where there may be no cost effective way to provide positive drainage outlets call for careful evaluation of local conditions and judgment in determining whether a drainage system should be included or not in each AC ramp structural section.

(2) Shoulder Structural Section. Ramp shoulder structural sections are to be designed in accordance with Index 604.4 except where ramp widening is required to handle truck off-tracking, see Index 404.1. In such cases, the full ramp structural section should extend to the outer shoulder edge of the widened ramp, see Index 504.3(1)(b).

For the design of ramp termini, see Index 603.6.

604.6 Structural Section Design for Intersections, Roadside Rests, and Parking Lots

Following the standard pavement structural section design procedure for intersections, roadside rests, and park and ride lots is not practicable because of the unpredictability of traffic. This topic provides specialized guidance and/or standard sections for these cases.

(1) Intersection Design. Where intersections have stop control or traffic signals and where trucks are present, special attention is needed to the design of flexible pavement to minimize shoving and rutting of the surface caused by trucks braking, turning, and accelerating. Separate designs should be developed for these intersections which may include thicker structural sections, alternative asphalt binders, aggregate sizes, or mix designs. PCC pavement is another alternative for intersections. Attention is also needed in providing sufficient traffic windows and/or modifications for materials to make sure that the pavement structural section placed has adequate time to cure before placing traffic or the next layer of structural section.

The limits for the pavement design of an intersection should include the intersection, intersection approaches, and intersection departures, to the greater of the distances stated below:

- For signalized intersections, the limits of the approach should extend past the furthest set of signal loop detectors where trucks do the majority of their braking.
- For stop controlled intersections the limits for the approach should be long enough to cover the distance trucks will be braking and stopping either at the stop bar or behind other trucks and vehicles.
- 30 meters.
- The limits for the intersection departures should match the limits of the approach in the opposing lane to address rutting caused by truck acceleration.

For further assistance on this subject, contact either your District Materials Engineer, METS – Office of Flexible Pavement Materials, or Division of Design – Office of Pavement Design.

- (2) *Roadside Rest Pavement Design.* Table 604.6A gives recommended thicknesses for the elements of structural sections to be used on entrance and exit ramps, roads, truck parking areas - including maintenance stations, facilities, maintenance pull-out areas, and auto parking areas in safety roadside rests. These standard sections should be used unless project site specific traffic information is available, in which case, the standard design procedure should be used. The surface of the parking areas in safety roadside rests should be crowned or sloped to minimize the amount of surface water penetrating into the structural section. Drainage facilities for the surface runoff should be provided.

TI assumptions have been made which are the basis for Table 604.6A. The structural sections are minimal, to keep initial costs down, but are reasonable because additional AC surfacing can be added later, if needed, and generally without incurring exposure to traffic or traffic handling problems. When stage construction is used to minimize initial costs, the full subbase and base thicknesses should be placed in the initial construction. Table 604.6A considers R-value of the basement soil as the only variable under each traffic usage classification. Safety factors were applied in the ramp design but not for the other areas.

- (3) *Park and Ride Lot Pavement Design.* The layer thicknesses shown in Table 604.6B are based on successful practice. These designs are minimal to keep initial costs down, but are considered reasonable since additional AC surfacing can be added later, if needed, without the exposure to traffic or traffic-handling problems typically encountered on a roadway.

The surface of Park and Ride Lots should be crowned or sloped to minimize the amount of surface water penetrating into the structural section. Drainage facilities for the surface runoff should be provided. A 9.5 mm or 12.5 mm maximum AC mix is recommended to provide a relatively low permeability. The AC pavement should be placed in one lift to provide maximum density.

Table 604.6A, Structural Sections for Roadside Rests, should be used in designing the structural section for areas of park and ride lots that will be used by buses and/or trucks. Unique conditions may require other special considerations.

Coal tar pitch emulsion treatment should not be applied to park and ride lots. However, a fog seal coat may be required after placing the AC, particularly if the facility will not be used immediately after construction.

604.7 Asphalt Concrete Pavement Maintenance and Rehabilitation

Policies and procedures governing AC pavement rehabilitation are contained in the Department's "Flexible Pavement Rehabilitation Manual," available from METS' Office of Pavement Rehabilitation or the District Materials Engineer. The "Flexible Pavement Rehabilitation Manual" may be accessed at: <http://www.dot.ca.gov/hq/oppd/pavement/guidance.htm>.

The Division of Maintenance has committed dedicated funding to pavement preservation. This pavement preservation funding implements a preventive maintenance program as a Departmental business practice. Preventive maintenance is applied to roadway surfaces in good condition. This effectively provides additional service life by minimizing the effects of weathering and reducing maintenance costs. For further information, contact the HQ Division of Maintenance.

Refer to the Maintenance Manual for preventive maintenance strategies and to the CAP-M guidelines for capital preventive maintenance strategies. CAP-M guidelines are available by contacting Headquarters Maintenance, Pavement Maintenance Managers.

Table 604.6A
Structural Sections for Roadside Rests
(Thickness of Layers¹ in mm)

Usage	TI	Material (Class) ³	R-value of Basement Soil									
			50 & Over	45-49	40-44	35-39	30-34	25-29	20-24	15-19-	10-14	5-9
Ramps & Truck Roads	8.0	AC	75	90	90	105	75	75	75	75	75	75
		CTB(A)	180	180	210	210	180	180	180	180	180	180
		AS(2)	0	0	0	0	105	120	165	195	240	270
		AC	105	105	105	105	105	105	105	105	105	105
		AB(2)	195	240	270	330	195	195	195	195	195	195
		AS(2)	0	0	0	0	105	150	195	225	270	300
		AC ²	195	210	225	240	255	270	285	285	285	300
Truck Parking Areas	6.0	AC	60	60	60	60	60	60	60	60	60	60
		AB(2)	135	165	195	210	135	135	135	135	135	135
		AS(2)	0	0	0	0	120	150	165	195	225	255
		AC ²	120	135	150	165	165	180	195	195	210	210
Auto Roads	5.5	AC	60	60	60	60	60	60	60	60	60	60
		AB(2)	120	135	165	180	210	120	120	120	120	120
		AS(2)	0	0	0	0	0	120	150	180	210	225
		AC ²	120	120	135	150	150	165	180	180	195	195
Auto Parking Areas	5.0	AC	45	45	45	45	45	45	45	45	45	45
		AB(2)	120	150	165	195	210	120	120	120	120	120
		AS(2)	0	0	0	0	0	105	135	165	180	210
		AC ²	90	105	120	120	135	135	150	165	165	180

Notes:

1. AC thicknesses of 75 mm or less must be placed in one lift.
2. Full Depth AC option (No base or subbase).
3. Structural section material options listed for each Usage, TI, and R-value are equivalent. The option chosen is the Project Engineer's decision based on recommendations from the District Materials Engineer, economics, and material availability.

**Table 604.6B
Structural Sections for
Park and Ride Lots**

R-Value Basement Soil	Thickness of Layers	
	AC* (mm)	AB (mm)
≥ 40	45	0
< 40	75	0
	45	105
≥ 40 and < 60	Penetration Treatment, using a liquid asphalt or dust palliative on compacted roadbed material. See Standard Specifications Section 93 or Section 18.	

* Place in one lift.

Topic 605 - Selection of Pavement Type

605.1 Introduction

The two types of pavement generally considered for new construction are rigid and flexible pavements as typified by Portland cement concrete (PCC) pavement and asphalt concrete (AC) pavement, respectively. There is no formula or clear-cut procedure which will produce a definite answer as to which pavement type is the most appropriate. In addition, because physical conditions are so variable and the influence of other factors differs significantly from location to location, projects must be studied individually. Therefore, the Project Engineer must consider the factors in Index 605.2, make certain assumptions, and use engineering judgment based on the best information available when determining which type or strategy to specify.

605.2 Pavement Type/Strategy Determination

The choice of pavement type or strategy should consider the following factors, which are listed and discussed in Appendix B of the 1993 AASHTO Guide for Design of Pavement Structures. These factors should be considered and addressed specifically in all project approval documents (PR, PSSR, etc.).

Primary factors listed are:

- Traffic,
- Soils characteristics,
- Weather,
- Construction considerations,
- Recycling, and
- Cost comparisons (initial and life-cycle).

No significance is attached to the order in which the factors are listed.

Secondary factors which may be pertinent, should also be considered and addressed. These factors include:

- Performance of similar pavements in the project area,
- Adjacent existing pavements,
- Conservation of materials and energy,
- Availability of local materials or contractor capabilities,
- Traffic and worker safety,
- Incorporation of experimental features,
- Stimulation of competition, and
- Municipal preference, participating local government preference, and recognition of local industry.

Pavement type selection may be dictated by specific project conditions such as:

- Predicted uneven foundation settlements or expansive soils dictate the use of AC,
- Groundwater or periodic inundation suggest the use of PCC pavement,
- Short freeway to freeway connections made between pavements of the same type,

- Existing pavement widening with a similar material,
- Traffic considerations,
- Stage construction, and
- Size of project less than 6.5 lane kilometers.

Another consideration that may have a possible effect on the final decision is the presence of grade controls, such as:

- Median barriers,
- Drainage facilities,
- Curbs and dikes
- Lateral and overhead clearances, and
- Structures which may limit the structural section design or rehabilitation strategies.

The pavement type selection should consider how these appurtenant features might affect the pavement structural section.

The new construction design and rehabilitation strategy should also minimize the exposure and maximize the safety of construction or maintenance forces and their equipment.

The final decision on pavement type should be the most economical design based on a life-cycle cost analysis (LCCA) which includes initial cost, maintenance cost, traffic delay cost and rehabilitation cost. At a minimum, a life-cycle cost analysis should be done for pavement type selection with $TI \geq 10$ unless the pavement type is dictated by specific project conditions (see Index 601.2 for examples).

After considering the various governing factors, alternative structural sections should be developed for economic analysis. If a detailed life-cycle cost analysis is not performed, a less comprehensive analysis must still be completed. This analysis is basically to determine the most economical structural section utilizing available structural section materials.

If a detailed LCCA is performed, it should follow the procedure in Index 605.3.

605.3 Life-Cycle Cost Analysis (LCCA)

LCCA is a useful tool for comparing the value of alternative structural sections and designs. It can be used both to compare the value of alternative designs for a given pavement service life and to compare alternative pavement service lives to determine which provides the optimum performance. LCCA comparisons must be made between properly designed, viable structural sections that would be approved for construction if selected. The structural section chosen in the economic comparison should be included in the final plans unless a revision is subsequently approved. In this event, a short memorandum is prepared referring to the original documentation, stating the details of the change, the reasons for the change, and the revised life-cycle costs. See Index 601.5 for documentation requirements.

(1) *General.* The economic comparison of structural sections should be based on total expected life-cycle cost. The following general guidelines should be used:

- (a) The structural sections to be compared should be shown by sketches so that quantities can be computed and checked.
- (b) A 35-year economic life-cycle period should be used for each project that is designed for a 20-year life. This assumes that the pavement structural section will be maintained and rehabilitated to carry the projected traffic over a 35-year period. The chart below provides for other analysis periods for different pavement service lives.

Pavement Service Life (years)	Economic Analysis Period (years)
10	20
20	35
30	45
40	50

- (c) A discount rate of 4% is used to convert costs to present worth.

- (d) Life-cycle costs are to be computed for the entire pavement structural section, including shoulders, for a length of one kilometer in one direction of travel on divided highways. The entire structural section is included for 2-lane roadways. Use one half of the normal maintenance cost per kilometer for divided highways.
- (2) *PCC Pavement Structural Section.* The life-cycle cost analysis for a PCC pavement structural section should include the following items as appropriate:
- (a) Initial Costs.
- PCC pavement,
 - Treated base (LCB, ACB, ATPB, CTPB)
 - Aggregate base (AB),
 - Aggregate subbase (AS),
 - PCC shoulders,
 - Shoulder base,
 - Shoulder subbase,
 - Structural section drainage system (TPB layer under PCC pavement and/or edge drains), and
 - Joint seals.
- (b) Maintenance Costs.
- Maintenance records should be obtained for cost data, including seal joints and cracks, undersealing to fill voids, repairing spalls, occasional slab replacement, etc., and
 - Traffic delay.
- (c) Rehabilitation Costs.
- Replacing slabs in truck lanes in year 15,
 - Placing AC overlay (preceded by slab cracking and seating) in year 25,
 - Engineering cost (preliminary and construction charges as percent of rehabilitation costs),
- Appurtenant and supplemental work (all work to be done to appurtenant drainage, safety, and other features made necessary by the rehabilitation work),
 - Traffic delay (obtain cost data from District Division of Planning),
 - Detours (may be included in appurtenant and supplemental work), and
 - Salvage value (estimated remaining service life of pavement or value of structural section materials).
- (3) *AC Pavement Structural Section.* The life-cycle cost analysis for an AC pavement structural section should include the following items:
- (a) Initial Cost.
- AC pavement,
 - Base (ACB, CTB, ATPB, CTPB, AB),
 - Aggregate subbase (AS),
 - AC shoulders,
 - Shoulder base,
 - Shoulder subbase, and
 - Structural section drainage system (TPB under AC pavement and/or edge drains)
- (b) Maintenance Cost.
- Maintenance records should be obtained for cost data, including thin AC blanket, chip seals, patching, sealing cracks, etc., and
 - Traffic delay.
- (c) Rehabilitation Cost.
- AC overlay for all lanes and shoulders once every 12 years,
 - Engineering cost (preliminary and construction charges as percent of rehabilitation costs determined from past district records),

- Appurtenant and supplemental work (all work to be done to appurtenant drainage, safety, and other features made necessary by the rehabilitation work),
- Traffic delay (obtain costs from District Division of Planning),
- Detours (may be included in appurtenant and supplemental work), and
- Salvage value (estimated remaining service life of pavement or value of structural section materials).

(4) *Present Worth Cost Calculation.*

$$PWC = IC + [(RC + EC + SC + DC) \times PWF \text{ No.1}] + (MC \times PWF \text{ No. 2}) - (SV \times PWF \text{ No. 3})$$

Where:

PWC	=	Present worth cost
IC	=	Initial costs
RC	=	Rehabilitation costs
EC	=	Engineering cost
SC	=	Supplemental work costs
DC	=	Traffic delay costs
PWF	=	Present worth factor
MC	=	Maintenance costs
SV	=	Salvage value

It is imperative that careful attention is given to the calculations involved and the data used in the calculations to ensure the most realistic and factual comparison between pavement types.

An economic life-cycle cost comparison outline for a 35-year period is presented in Table 605.3.

Topic 606 - Drainage of the Pavement Structural Section

606.1 Introduction

Distress in both flexible and rigid pavements is generally caused by exposure to heavy truck traffic when the pavement structural section is in a saturated condition. Saturation of the structural section or underlying foundation materials, or both, generally results in a decrease in strength or ability to support truck axle loads. Potential problems associated with saturation of the structural section and the subgrade foundation include:

- Pumping action,
- Differential expansion (swelling) of expansive subgrade soils,
- Frost damage in freeze-thaw areas,
- Erosion and piping of fine materials creating voids which result in the loss of subgrade support,
- Icing of pavement surface from upward seepage,
- Stripping of asphalt concrete aggregates, and
- Accelerated oxidation of asphalt binder.

Water can enter the structural section as surface water through cracks, joints, and pavement infiltration, and as groundwater from an intercepted aquifer, a high water table, or a localized spring. Both sources of water should be considered and provisions should be made to handle both. The structural section drainage system, which is designed to handle surface water inflow, is generally separate from the subsurface drainage system that is designed to accommodate encroaching sub-surface water. Local rainfall data should be used in the design of the roadway drainage system as discussed in Chapter 830 of this manual.

Table 605.3
Life-Cycle Economic Comparison of Pavement Types
(Variable-Year Analysis Period and 4% Discount Rate)

ALTERNATIVE 1		Cost Per Kilometer With Shoulders	
Initial Cost =			\$(_A_)
Rehabilitation Costs in Year ____:			
Repair Cost =		\$(_b_)	
Engineering	\$(_b_)(0.1225) =	\$(_)	
Appurtenant and Supplemental Work	\$(_b_)(0.1350) =	\$(_)	
Traffic Delay =		\$(_)	
		\$(_c_)	
Present Worth Cost of Rehabilitation Work in Year ____		\$(_c_) (PWF) =	\$(_C_)
Rehabilitation Costs in Year ____: ****			
Repair Cost =		\$(_d_)	
Engineering	\$(_d_)(0.1225) =	\$(_)	
Appurtenant and Supplemental Work	\$(_d_)(0.1350) =	\$(_)	
Traffic Delay =		\$(_)	
		\$(_e_)	
Present Worth Cost of Rehabilitation Work in Year ____		\$(_e_) (PWF) =	\$(_E_)
Annual/Average Maintenance over ____ years (See Index 605.3(2)(b))		\$(_*) (16.3742) =	\$(_F_)
Subtotal (A+C+E+F)			\$(_)
Less Salvage Value (of rehabilitation)** (Variable Ratio)		\$(_c_)(PWF) =	- \$(_)
PCC Pavement Net Present Worth Cost			\$(_)
ALTERNATIVE 2		Cost Per Kilometer With Shoulders	
Initial Cost =			\$(_G_)
Rehabilitation Costs in Year ____:			
Repair Cost =		\$(_h_)	
Engineering	\$(_h_)(0.1225) =	\$(_)	
Appurtenant and Supplemental Work	\$(_h_)(0.1350) =	\$(_)	
Traffic Delay =		\$(_)	
		\$(_i_)	
Present Worth Cost of Rehabilitation Work in Year ____		\$(_i_) (PWF) =	\$(_I_)
Present Worth Cost of Rehabilitation Work in Year ____		\$(_i_) (PWF) =	\$(_J_)
Annual/Average Maintenance over ____ years (See Index 605.3(3)(b))		\$(_*) (16.3742) =	\$(_K_)
Subtotal (G+I+J+K)			\$(_)
Less Salvage Value (of Resurfacing) ** (Variable Ratio)		\$(_i_)(PWF) =	- \$(_)
ALT2 Net Present Worth Cost			\$(_)
Savings Per Kilometer Using (ALT1/ALT2) [Circle appropriate alternative]			\$(_)

NOTES

- * As an initial estimate, use the average annual district maintenance cost for the respective type of pavement (use WIMS Data).
- ** Salvage Value Assumptions: **For purposes of this example**, the original PCC pavement is expected to require some type of rehabilitation work at 15 and 25 years. At the end of the 35-year comparison, the second rehabilitation is expected to serve 2 years longer. This provides a salvage value of 2/12 the cost of the second rehabilitation. The original AC pavement is expected to require resurfacing or recycling in 12 and 24 years, and the AC overlay or recycling is assumed to last 12 years for a total service of 36 years.
- *** The above format is an example of an outline for guidance only. Actual rehabilitation strategies for a specific project should be used. Refer to Pavement website – “LCCA” for further discussion.
- **** Repeat as necessary over pavement analysis period.

The estimated sub-surface water inflow can be determined by a combination of field investigations, analytical techniques, and graphical methods. "Subsurface Drainage" is discussed in Chapter 840. The Materials Report contains findings on subsurface conditions and recommendations for design. The District Materials Engineer and Division of Design can provide assistance in developing appropriate features in the plans and specifications to address the problem of water in the structural section.

606.2 Structural Section Drainage Practices

- (1) *New Construction Projects.* The structural section should include a layer of Treated Permeable Base (TPB) under the pavement except in areas where the mean annual rainfall is very low (less than 125 mm) or where the basement soil is free draining (a permeability greater than 3.53×10^{-4} m/s). The surface of the traveled way and shoulders should employ materials that will prevent surface water intrusion and any joints should be sealed. If sufficient right of way is available, it is desirable to grade the roadbed to allow for a free draining outlet for the structural section. The TPB, AB and AS layers of the structural section extend the full width of the roadbed (see Figure 606.2).
- (2) *Widening and Reconstruction Projects.* The widened structural section layers should conform to the existing structural section layers to perpetuate existing drainage. The widened layers should extend the full width of the roadbed to a free outlet, if feasible, as in new construction. (See Figure 606.2). Joints should be sealed as discussed in Index 603.7.
- (3) *Rehabilitation Projects.* The surface of the traveled way and shoulders should employ methods and materials that will help prevent surface water intrusion and any joints should be sealed. Existing structural section drainage should be perpetuated or restored, if feasible.

606.3 Drainage Components and Related Design Considerations

The basic components of a pavement structural section drainage system are:

- Drainage layer.
- Collector system.
- Outlets, vents, and cleanouts.
- Filter Fabric (Selected for project specific soil conditions)
- Storm Water Management

- (1) *Drainage Layer.* A drainage layer consisting of either 75 mm of asphalt treated permeable base (ATPB) or 105 mm of cement treated permeable base (CTPB) should be placed immediately below the pavement for interception of surface water that enters the structural section. The drainage layer, base, and subbase should extend the full width of the roadbed (see Figure 606.2). If constraints exist, then the drainage layer should utilize a collector system of edge drains and collector pipes (see Figure 606.2).

When there is concern that the infiltrating surface water may saturate and soften the underlying subbase or subgrade (due either to exposure during construction operations or under service conditions) a filter fabric or other suitable membrane should be utilized. It should be applied to the base, subbase, or subgrade on which the TPB layer is placed to prevent migration of fines and contamination of the TPB layer by the underlying material.

Either of the standard ATPB or CTPB layers (75 mm or 105 mm respectively) will generally provide greater drainage capacity than is needed. The standard thicknesses are based primarily on constructability with an added allowance to compensate for construction tolerances. If material other than ATPB or CTPB with a different permeability is used, it is necessary to check the permeability and adequacy of the layer thickness.

Figure 606.2
Typical Section with Treated Permeable Base
Drainage Layer

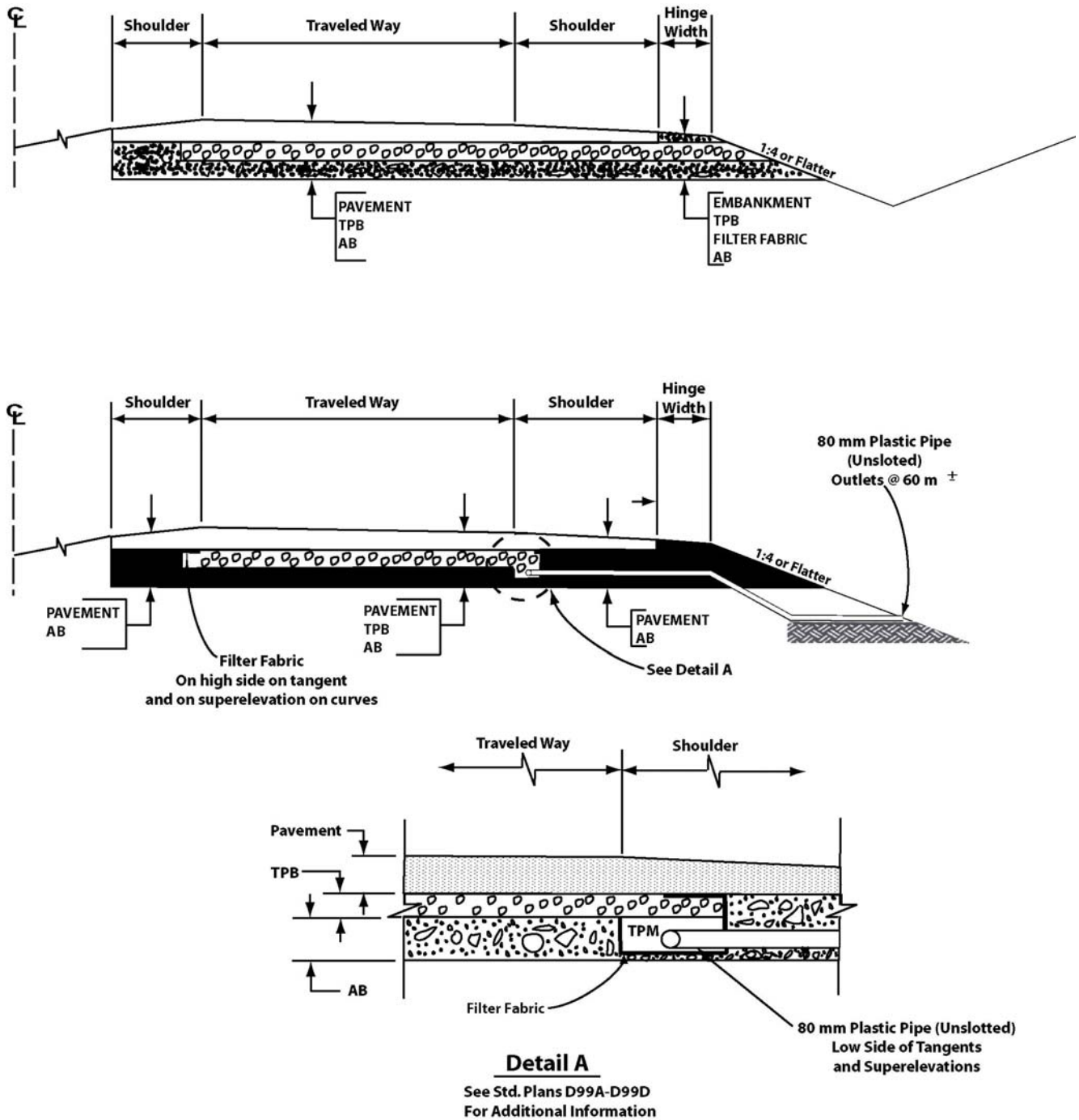

- NOTES:
1. Section shown is a half-section of a divided highway. An edge drain collector and outlet system should be provided if insufficient Right of Way precludes a retention basin.
 2. This figure is only intended to show typical pavement structural section details, for geometric cross section details, see Chapter 300.

When using TPB, special attention should be given to drainage details wherever water flowing in the TPB encounters impermeable abutting structural section layers, a bridge approach slab, a sleeper slab, a pavement end anchor, or a pressure relief joint. In any of these cases, a cross drain interceptor should be provided.

Details of cross drain interceptors at various locations are shown in Figure 606.3A. The cross drain outlets should be tied into the longitudinal edge drain collector and outlet system with provision for maintenance access to allow cleaning.

When TPB is encountered as a drainage layer in widening of a facility, the TPB should be perpetuated so water is not trapped within the structural section.

- (2) *Structural Section Design Considerations.* The standard flexible pavement design procedure, as covered under Index 604.4, is followed to develop AC pavement structural sections which incorporate a drainage layer to accommodate surface infiltration. A gravel factor (G_f) of 1.4 is used for ATPB with a standard thickness of 75 mm. A standard thickness of 105 mm is used for CTPB with a G_f of 1.7. Because of their relative rigidity, no R-value is assigned to either ATPB or CTPB and the design is handled in the same manner as Class A CTB. For design examples see Structural Section Design Examples on the Design Pavement website <http://www.dot.ca.gov/hq/oppd/pavement/guidance.htm>.
- (3) *Collector System.* Where it is not practical to drain water out of the structural section by other means, an 80 mm slotted plastic pipe edge drain should be installed in a longitudinal collector trench as shown in Figure 606.2. In areas where the profile grade is equal to or greater than 4%, intermediate cross drain interceptors, as shown in Figure 606.3B should be provided at an approximate spacing of 150 m. This will limit the longitudinal seepage distance in the drainage layer, minimizing the drainage time and preventing the buildup of a hydrostatic head under the

surface layer. Cross drain interceptor trenches must be sloped to drain.

In addition, cross drains need to be provided at the low-end terminal of TPB projects, as shown in Figure 606.3B. Care should be taken to coordinate the cross drains with the longitudinal structural section drainage system. Drainage layers in roadway intersections and interchanges may require additional collector trenches, pipes, and outlets to assure rapid drainage of the structural section.

A standard longitudinal collector trench width of 0.3 m has been adopted for new construction to accommodate compaction and consolidation of the TPB alongside and above the 80 mm slotted plastic pipe. The TPB type (cement or asphalt treated) for use in the collector trenches will be at the contractor's option.

Filter fabric should be placed as shown in Figures 606.2 and 606.3A, respectively, to provide protection against clogging of the TPM by intrusion of fines. Filter fabric should be selected based upon project specific materials conditions to ensure continuous flow of water and preclude clogging of the filter fabric openings. Consult with METS' Office of Pavement Rehabilitation to assist in selecting the most appropriate filter fabric for the project.

On curvilinear alignments, superelevation of the roadway may create depressions at the low side of pavement where the collected water cannot be drained away. An adjustment to the profile grade may be necessary to eliminate these depressions. Refer to Chapter 200 for superelevation design guidelines.

When a superelevation cross slope begins to drain the water through the TPB to the low side of pavement in cut sections, an edge drain system may be considered to direct water to an area where ponding will not occur.

- (4) *Outlet Pipes.* When edge drains are used, plastic pipe (unslotted) outlets should be provided at proper intervals for the pavement structural section drainage system to be free draining. The spacing of outlets (including

vents and cleanouts) should be approximately 60 m (75 m maximum). Outlets should be placed on the low side of superelevations or blockages such as bridge structures.

The trench for the outlet pipe must be backfilled with material of low permeability, or provided with a cut-off wall or diaphragm, to prevent piping.

The outlets must be daylighted, connected to culverts or drainage structures, or discharged into gutters or drainage ditches. The area under the exposed end of a daylighted outlet should have a splash block or be paved to prevent erosion and the growth of vegetation, which will impede flows from the outlet. Ready access to outlets, and the provision of intervening cleanouts when outlet spacing exceeds a maximum distance of 75 m, should be provided to facilitate cleaning of the structural section drainage system. Typical details are shown on the Standard Plans for Edge Drain Outlet and Vent Details.

The end of each outlet pipe should be indicated by an appropriate marker to facilitate location and identification for maintenance purposes and to reduce the likelihood of damage by vehicles and equipment. Consult the District Division of Maintenance for the preferred method of identification.

- (5) *Storm Water Management.* Drainage emanating from either the pavement surface or from subsurface drains (edge drains, underdrains, and daylighting of the structural section layers) is to be handled in accordance with the procedures provided in Chapter 800 of the HDM for conveyance and with the procedures in the Project Planning and Design Guide (PPDG) for treatment consideration. Storm water Best Management Practices (BMP's) are to be incorporated in the design of projects as prescribed in the PPDG.

Topic 607 - Structure Approach Pavement and Structure Abutment Embankment Design

607.1 Introduction

The ultimate goal of structure approach slab design is to provide a smooth transition between a pavement that is generally supported on a yielding medium (soil that is subject to consolidation and settlement) and a structure, which is supported on a relatively unyielding foundation (piling or spread footings).

The approaches to any structure, new or existing, often present unique geometric, drainage, structural section, and traffic situations that require special design considerations.

Adequate information must be available early in the project development process if all factors affecting the selection and design of a structure approach system are to be properly assessed. A field review will often reveal existing conditions, which must be taken into consideration during the design.

These design guidelines must be followed in the design of all projects involving new construction, reconstruction, or rehabilitation of structure approaches. They are not, however, a substitute for engineering knowledge, experience, or judgment.

607.2 Functional Area Responsibilities

- (1) *Project Engineer* - The Project Engineer (PE) is responsible for the Plans, Specifications, and Estimate (PS&E) of all structure approach contract items below the grading plane, except for the contiguous drainage system components placed within the abutments and wingwalls. The PE is responsible for PS&E of drainage outside the abutments and wingwalls. The PE is also responsible for coordinating and reviewing the adequacy of all drainage ties between the structure approach drainage features and other new or existing drainage facilities.

The PE should contact the Structures District Liaison Engineer as early as possible in the project development process to facilitate project scheduling. The PE must provide pertinent site information and traffic staging plans to DES and may submit recommendations concerning the need for concrete approach systems. Close coordination between the District staff and DES staff is necessary for the proper selection and design of a structure approach system.

- (2) *Division of Engineering Services* – The DES is responsible for the PS&E of all structure approach contract items above the grading plane and for the drainage system components placed within the abutments and wingwalls. Coordination between DES and the District should be as discussed in Index 607.2(1). Questions concerning approach slab design should be directed to DES. Figures 607.4, 607.5A and 607.5B show diagrammatically the structure approach features which are DES responsibilities. When the construction or rehabilitation of a concrete pavement approach is necessary, the DES is responsible for selecting the type of concrete approach system to be used. On new construction projects, the DES is responsible for determining whether or not a concrete pavement approach system is used at each bridge site. On rehabilitation projects, the Pavement Rehabilitation Scoping Team will recommend whether or not replacement or construction of a PCC approach slab(s) is necessary. The Pavement Rehabilitation Scoping Team is comprised of the Project Engineer, District Maintenance, other District functional unit representatives, Headquarters Program Advisors and others as needed.
- (3) *Office of Structural Foundations (OSF)* - Provides the Districts, Structures, and Headquarters with expertise in foundation investigations. Prepares Geotechnical Design Reports recommending estimates of settlement by areas, specific recommendations for foundation treatment, and a history of the performance of structure abutment foundations and embankments in the same area. The OSF Structure Foundation Branch on new construction projects should perform a foundation investigation and analysis. At the request of the DES, the OSF Roadway Geotechnical Engineering Branch will prepare a Geotechnical Design Report based upon its studies and information supplied by the District. The report should include a summary of field investigations, estimate of settlement by areas, specific recommendations for foundation treatment, and a history of the performance of structure abutment foundations and embankments in the same area. All foundation and embankment recommendations by the OSF Branches must be carefully followed in development of the project PS&E or documented as to why they were not followed.
- (4) *District Materials Engineer* - Responsible for materials information requested for each project from Planning through Maintenance. Prepares the District Materials Report for each project. Continuous consultation with the PE and Construction should take place. Coordinates Materials information with Caltrans functional units, METS, Headquarters functional units, local agencies, industry, and consultants. The District Materials Unit is responsible for conducting a preliminary soils investigation, which addresses the quality of the materials available in and under the roadway prism for constructing the project. Poor quality material, such as expansive soils, must be precluded from structure abutment embankments. If sufficient quality roadway excavation material is unavailable for constructing structure abutment embankments, the designer may specify select material, local borrow or imported borrow to satisfy the design requirements.
- (5) *Traffic Operations* - Recommends Traffic Management Plans (TMP's) and assists in the determination of construction windows. On approach slab rehabilitation projects, complete investigations by the District Division of Traffic Operations will be necessary to assess the impact of lane closures and detours on the traveling public.

607.3 Structure Approach Embankment

Structure approach embankment is that portion of the fill material within approximately 50 m longitudinally of the structure. Refer to Figure 607.3 for limits, the Standard Specifications, and other requirements.

Quality requirements for embankment material are normally specified only in the case of imported borrow. When select material or local borrow for use in structure abutment embankments is shown on the plans, the Resident Engineer (RE) is responsible for assuring the adequacy of the quantity and quality of the specified material. The RE File should include adequate information and guidance to assist the RE in fulfilling this responsibility.

607.4 Structure Approach Pavement Systems

Concrete pavement structure approach systems are used on all Portland cement concrete (PCC) pavements and on multilane asphalt concrete (AC) pavements located within currently designated urbanized areas. Urbanized areas are identified, by kilometer post, in the Route Segment Report, Project Management Control System (PMCS) Data Base and State Highway Inventory. The current boundaries of urbanized areas are also shown on the official State Highway Map.

There are several pavement slab alternatives that may be considered in the design of a structure approach pavement system. These alternatives are designated Types 14, 9, and 3 structure approach systems. Standard details and special provisions have been developed for each type of approach system. DES will select the appropriate alternate and provide applicable details, specifications, and an estimate of cost for inclusion in the PS&E package. It is recommended that dowel bars be placed at the transverse joint of PCC pavement where the pavement and approach slab meet to ensure load transfer at the joint. The thinner of either the pavement or the approach slab will govern placement of the dowel at half the thickness of the thinner slab.

On all new construction projects, regardless of the type of structure approach selected, provisions for positive drainage of the approach system are to be incorporated into the design. (See Structures Design Standard Details for requirements.)

On rehabilitation projects, provisions for positive drainage of the structural section must be incorporated into the structure approach design.

On new construction projects, overcrossing structures constructed in conjunction with the State highway facility should receive the same considerations as the highway mainline.

A brief discussion of the types of structure approach pavement systems follows:

(1) *Type 14 Structure Approach System (Approach and Sleeper Slabs/Drainage)*. The Type 14 system includes a 9 m long reinforced concrete pavement slab and a 4.5 m long structure approach sleeper slab (see Figure 607.4). The structure approach system extends laterally across all traffic lanes and shoulder areas. The approach slab is designed to either cantilever over (preferred) or extend to the inside faces of both abutment wingwalls.

The Type 14 approach system is used only on new construction with structures having diaphragm type abutments. It is primarily used on PCC pavement but may be used on AC pavement if warranted by special site conditions.

(2) *Type 9 Structure Approach Pavement System (Approach Slab/Drainage)*. This approach slab is a 9 m long reinforced concrete pavement slab which rests on and is tied to the structure abutment backwall or paving notch. The slab extends laterally across all traffic lanes and shoulder areas. The approach slab is designed to either cantilever over or extend to the inside faces of both abutment wingwalls.

Figure 607. 3
Limits of Structure Approach Embankment Material

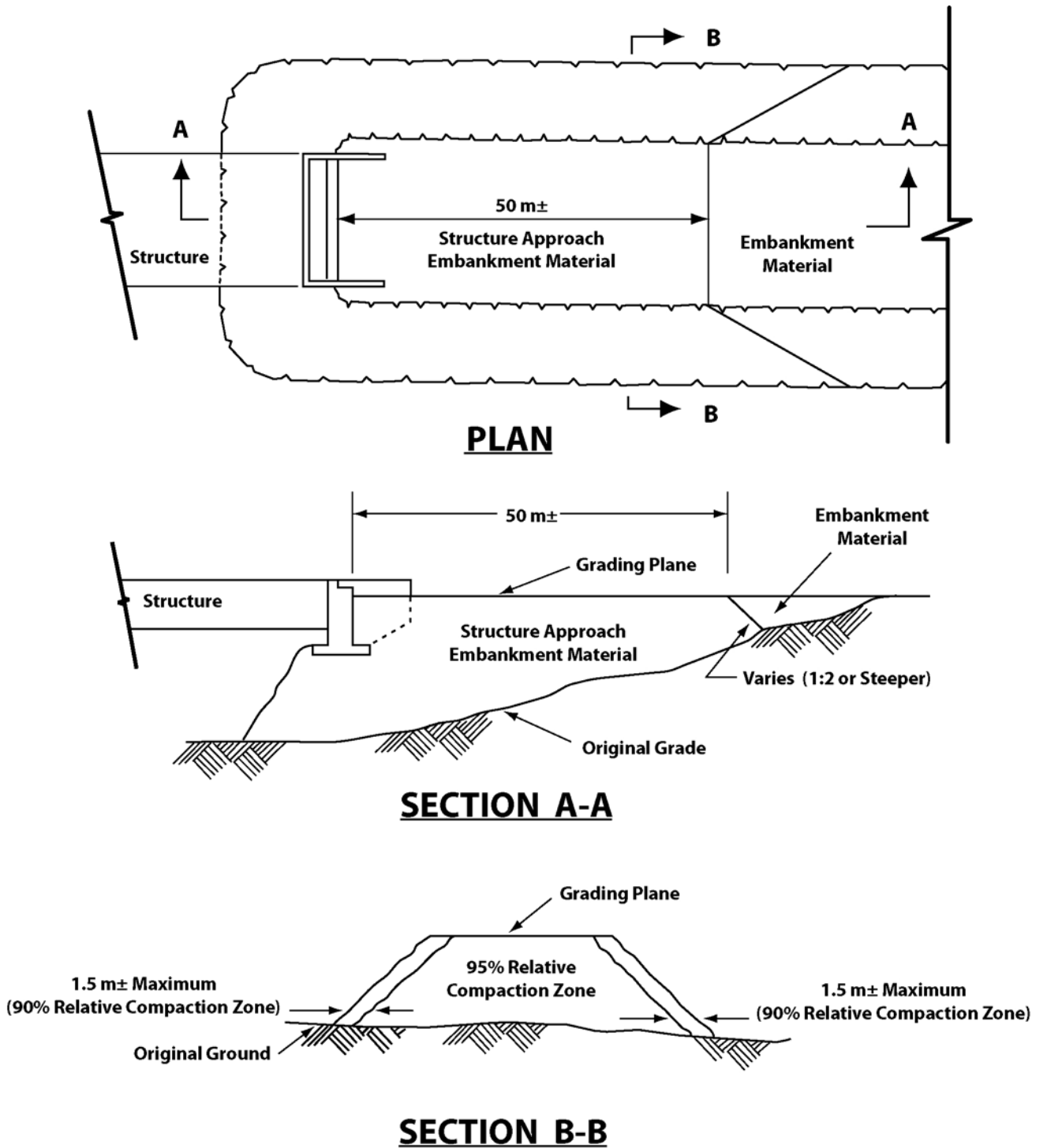
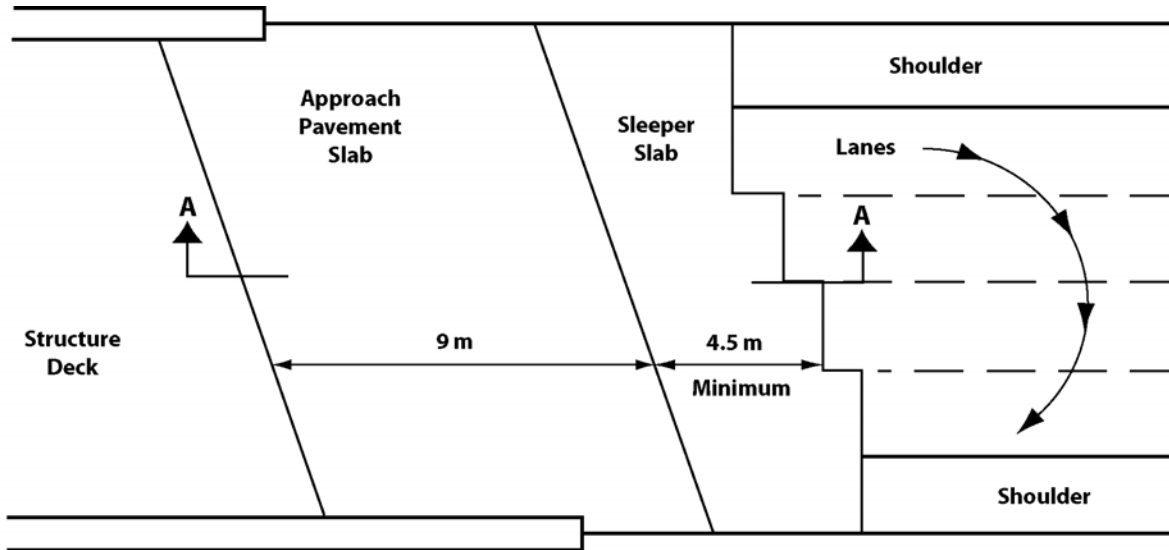
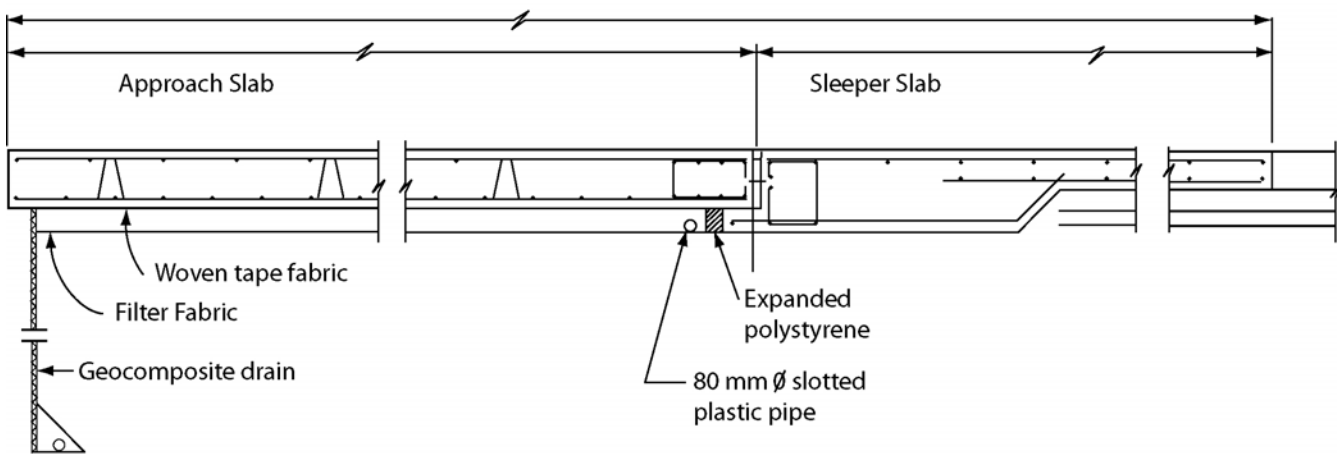

Figure 607.4
Type 14 Structure Approach Layout



Plan View



SECTION A-A

The Type 9 system is the design standard for new construction at structures with seat type abutments. The Type 9 system is also adaptable to diaphragm type abutments where the Type 14 approach system may be inappropriate. The Type 9 slab is the standard rehabilitation treatment at structures with either diaphragm or seat type abutments.

- (3) *Type 3 Structure Approach Pavement System - Earthquake Zones (Seismic Ramp Slab)*. The Type 3 structure approach slab, 3 m in length, is used only on AC pavement located within areas of high magnitude seismic activity. This approach slab is designed to provide a ramp to accommodate the passage of motor vehicles over the structure in the event that an earthquake creates settlement of the structure abutment embankment and approach pavement. The Type 3 seismic ramp slab is provided when both the following conditions (a) and (b) exist or when the following condition (c) exists:
- (a) Peak rock acceleration is estimated to be 0.6 x gravity or greater, as documented in the Geotechnical Design Report, District Materials Report or Foundation Report.
 - (b) Approach embankment or fill height exceeds 3 m.
 - (c) Geologic conditions, as documented in the Geotechnical Design Report, District Materials Report, or Foundation Report, indicate the need for a seismic approach ramp.

If an alternate and convenient route is available for use by emergency vehicles, the use of the Type - 3 structure approach system is not necessary.

607.5 Structure Approach Pavement System - New Construction

- (1) *Foundation and Embankment Design*. The structural stability and overall performance of the structure approach system depends, to a significant degree, upon the long-term settlement/consolidation of the approach foundation and structure abutment embankment. A design that minimizes this

post construction settlement/ consolidation is essential. Factors that influence settlement/ consolidation include soil types and depths, static and dynamic loads, ground water level, adjacent operations, and changes in any of the above. The PE must carefully follow all foundation and embankment recommendations by the OSF Branches and District Materials Unit, and any deviations from their recommendations must be approved by them.

The relative compaction of material within the embankment limits must not be less than 95%, except for the outer 1.5 m of embankment measured horizontally from the side slope. The District Materials Engineer or OSF may recommend using select material, local and/or imported borrow to assure that the compaction requirements are met and that shrink/swell problems are avoided. They may also recommend a height and duration of embankment surcharge to accelerate foundation consolidation.

- (2) *Abutment Details*. The Type 14 approach slab is rigidly tied to the structure abutment and acts as an extension of the structure. Any movement of the abutment will also occur in the approach slab. A sealed joint between the approach slab and the sleeper slab, parallel to and 9 m from the abutment wall, provides for this movement.

The Type 9 approach system is used at structures having either diaphragm or seat type abutments. At a diaphragm type abutment, structure movement is accommodated at the sealed joint between the approach slab and abutment. Structure movement at a seat type abutment will occur at the structure side of the abutment. The structure/abutment joint is designed to handle the movement.

The Type 3 approach system is also used at both seat and diaphragm type abutments. Various abutment/slab tie details are available to accommodate structure movement.

- (3) *Structure Approach Drainage*. Special attention must be given to providing a positive drainage system that minimizes the potential

for water damage to the structure approach embankment. The following features should be included:

(a) Abutment and Wingwall Drainage

A geocomposite drain covered with filter fabric is used behind both the abutment wall and wingwalls, as indicated in Figures 607.4, 607.5A and 607.5B.

A slotted plastic pipe drain, encapsulated with treated permeable material, is placed along the base of the inside face of the abutment wall as illustrated in Figure 607.5B. A pipe outlet system carries the collected water to a location where it will not cause erosion. Storm Water Best Practices should be incorporated. Coordination with DES is necessary for the exit location of the pipe system. The outlet type should be chosen from the standard edge drain outlet types shown in the Standard Plans. The PE must review the drainage design to insure the adequacy of the drainage ties between the abutment and wingwall drainage system and either new or existing drainage facilities.

(b) Structural Section Drainage

Figure 607.4 shows the components of the positive structural section drainage system. Filter fabric should be placed on the grading plane to minimize contamination of the TPB for all types of approach systems. For the Type 14 approach system, a transverse slotted plastic pipe is installed in the treated permeable layer under the approach slab and adjacent to the sleeper slab to intercept water that enters through this joint. The plastic pipe shall have a proper outlet to avoid erosion of the structure approach embankment. Storm Water Best Practices should be incorporated. The Districts are responsible for all drainage considerations of the roadway while DES Structures is responsible for structure related drainage.

(c) Surface Drainage

Roadway surface drainage should be intercepted before reaching the approach/

sleeper slab; likewise, structure deck drainage, when practicable, should be intercepted before reaching the abutment joint or paving notch. Cross drain interceptors are discussed in Index 606.3(3) and shown in Figures 606.2B and 606.3. The objective is to keep water away from the structure approach embankment. The surface water, once collected, should be discharged at locations where it will not create erosion.

Containment of surface drainage requires special treatment when the approach slab edge extends only to the inside faces of the abutment wingwalls. A 76 mm x 76 mm x 6.4 mm galvanized steel angle (see Figure 607.5A), pourable seal, and hardboard spacer prevent water from entering the structural section and embankment. On wingwalls longer than 9 m, the angle is terminated at the sealed joint between the approach slab and the sleeper slab. A 155 mm x 6.4 mm steel plate will be used instead of angle for the single slope barriers such as concrete barrier Type 732 or Type 736.

When a dike is required to protect the side slope from erosion, it should be placed on the approach and sleeper slabs and aligned to tie into the end of the structure railing. The guardrail alignment and edge of shoulder govern the positioning of the dike.

When the Type 14 approach system is used, an AC dike will inevitably crack due to expansion and contraction at the approach/sleeper slab joint. PCC dikes may be considered for this application. A metal dike insert is used to carry the flow across the sealed joint. The insert acts as a water barrier to minimize erosion of the fill slope. Details of the metal dike insert are shown in the structure approach plans provided by DES. Index 837.3(2) should be referenced when drainage inlets are to be placed at bridge approaches and departures.

Figure 607.5A
Approach Slab Edge Details

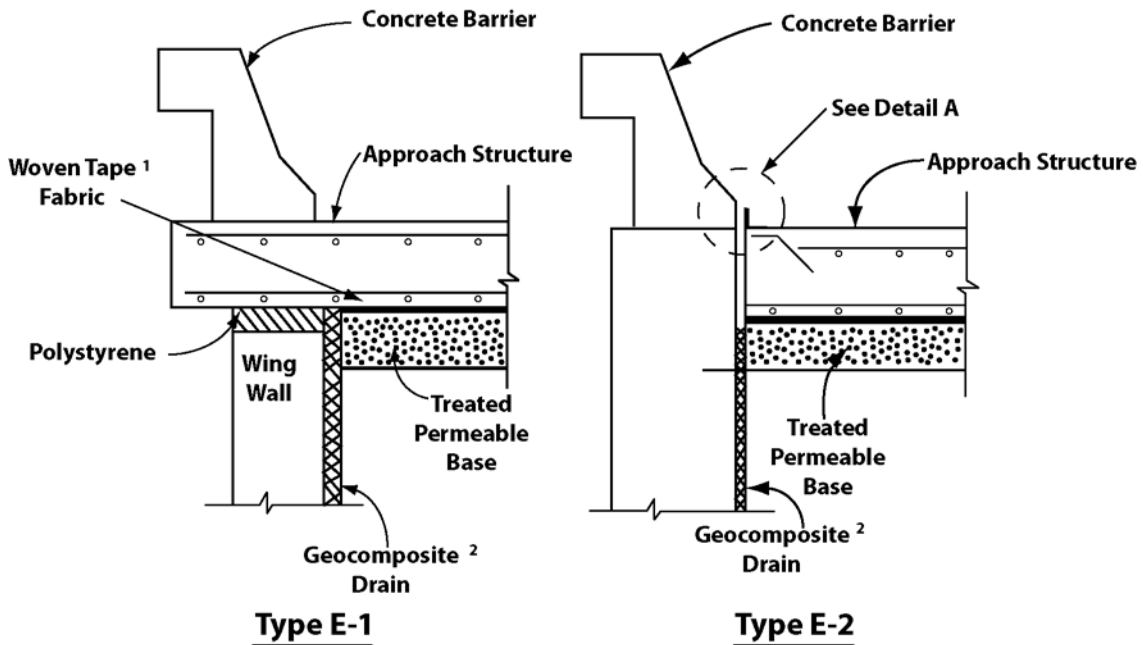

NOTES:

1. Applicable to Type 14 Structure Approach Systems only.
2. Applicable to new construction only.

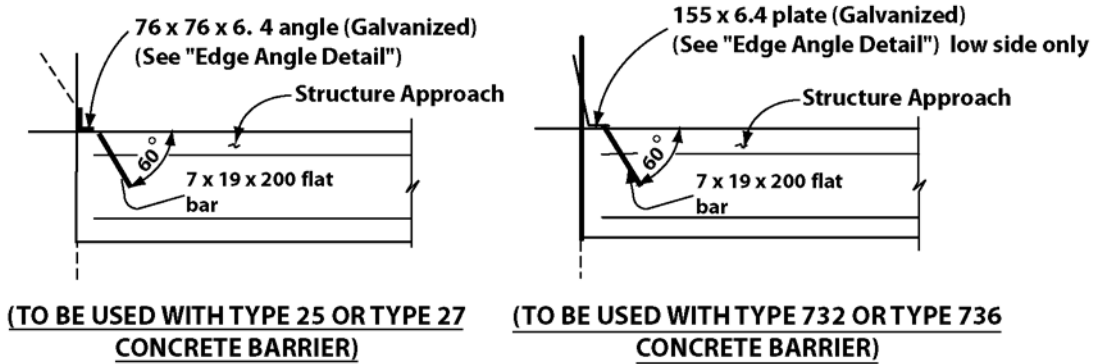

DETAIL A

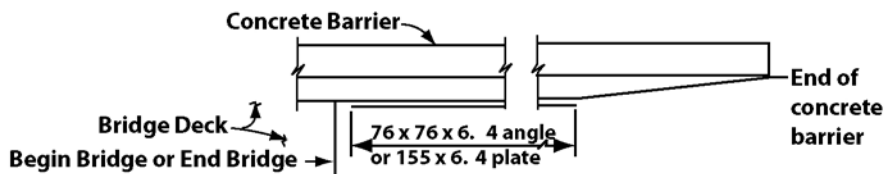

EDGE ANGLE DETAIL

Figure 607.5B
Abutment Drainage Details*

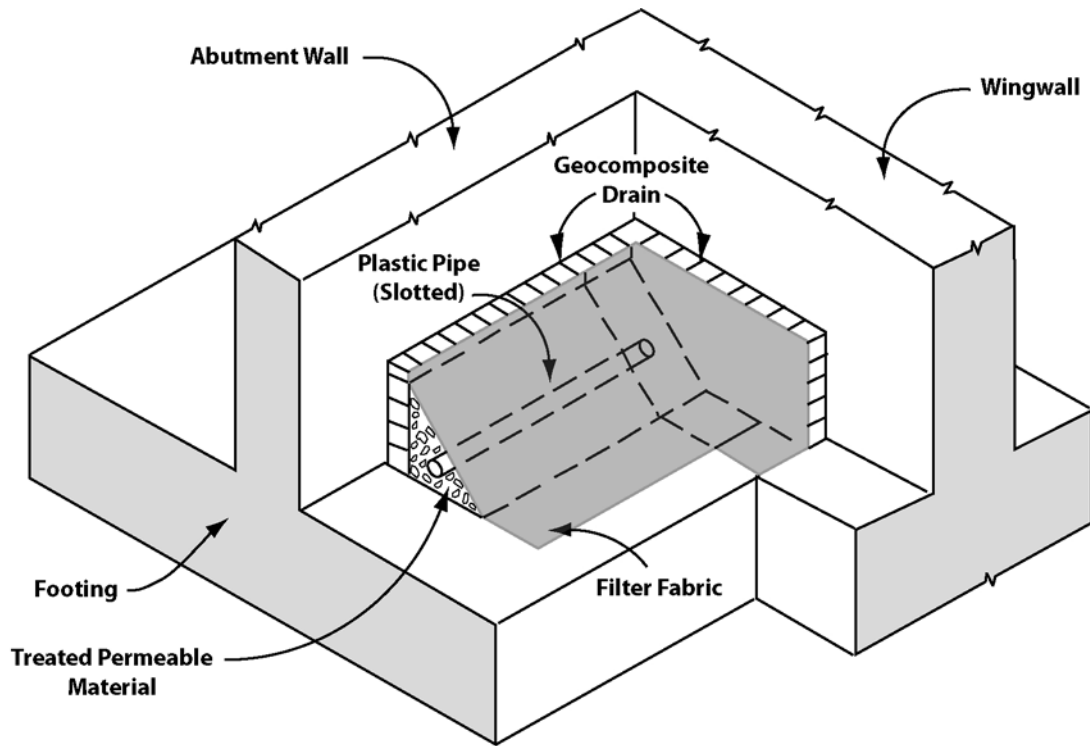

***NOTE: Applicable to new construction only.**

- (4) *Pavement Details.* Approach/sleeper slabs extend the full width of the traveled way and shoulders. On new construction, or rehabilitation work where the structure railing will be replaced, the approach slab extends laterally to coincide with the edge of the structure superstructure. The slab extends over the wingwall, but is separated from the top of the wingwall by polystyrene fillers to preclude vertical loading of the wingwalls when settlement of the embankment occurs. The new structure railing is then attached to the approach slab.

The Type 14 approach slab system utilizes a woven tape fabric, which is used as an interlayer separator on top of the treated permeable base to reduce friction and accommodate movement of the approach slab. The sleeper slab functions as a bearing surface for the approach slab in the event that settlement/consolidation of the structure abutment foundation or embankment occurs. The sleeper slab also functions as a transition slab to the pavement structural section.

Any longitudinal construction joints (cold joints) required during construction of the structure approach or sleeper slabs should be placed on lane lines. The contact joint at the end of the sleeper slab is normal to the centerline. Transverse joints may be staggered at the lane lines at skewed structures; as illustrated in Figure 607.4. The stagger may occur 7.2 m or 10.8 m apart for skews of 20 to 45 degrees and at each lane line for skews greater than 45 degrees.

Structural adequacy must be met under the approach slabs.

- (5) *Guardrail.* The extension of the approach and sleeper slabs across the full width of the outside shoulder creates a conflict between the outside edge of these slabs and the standard horizontal positioning of some guardrail posts. Spacers are attached to the posts that conflict with the approach and sleeper slabs to move the postholes outside the edge of shoulder without changing the standard alignment of the guardrail. These details are covered by DES Standard Details and by Standard Plans.

607.6 Structure Approach Slab - Rehabilitation Projects

- (1) *Approach Slab Replacement.* The Type 9 approach slab is the primary rehabilitation standard for both PCC pavement and AC pavement. The Type 3 approach slab may be used on AC pavement only, if warranted by special site considerations (see Index 607.4(3)).

Replacement of a PCC approach slab consists of removing the existing pavement, approach slab, cement treated base and subsealing material (if applicable) and then replacing with an appropriate type of structure approach system. Depending on the thickness of the existing pavement and base materials to be removed, the minimum 300 mm approach slab thickness (Type 9 approach system) may have to be increased.

- (2) *Structure Approach Structure Section Drainage.* Typical details for positive drainage of a full-width structure approach system are shown in Figure 607.6A. Cross drains are placed at the abutment backwall and at the transverse joint between the existing pavement and the concrete approach slab. A collector/outlet system is placed adjacent to the wingwall at the low side of pavement. The collected water is carried away from the structure approach embankment to a location where it will not cause erosion. Storm Water Best Practices should be implemented.

The approach slab edge details to prevent entry of water at the barrier rail face (see Figure 607.5A- Type E2) apply when the wingwalls and/or bridge barrier railing are not being reconstructed.

- (3) *Pavement Details.* Special pavement details are necessary when PCC approach slabs will be replaced in conjunction with the crack, seat, and AC overlay pavement rehabilitation strategy for PCC pavement. Figure 607.6B, which is applicable to full-width slab replacement, illustrates a method of transitioning from the typical 105 mm AC overlay thickness to the minimum 45 mm final AC lift thickness. Care should be taken in

Figure 607.6A
Structure Approach Drainage Details
(Rehabilitation)

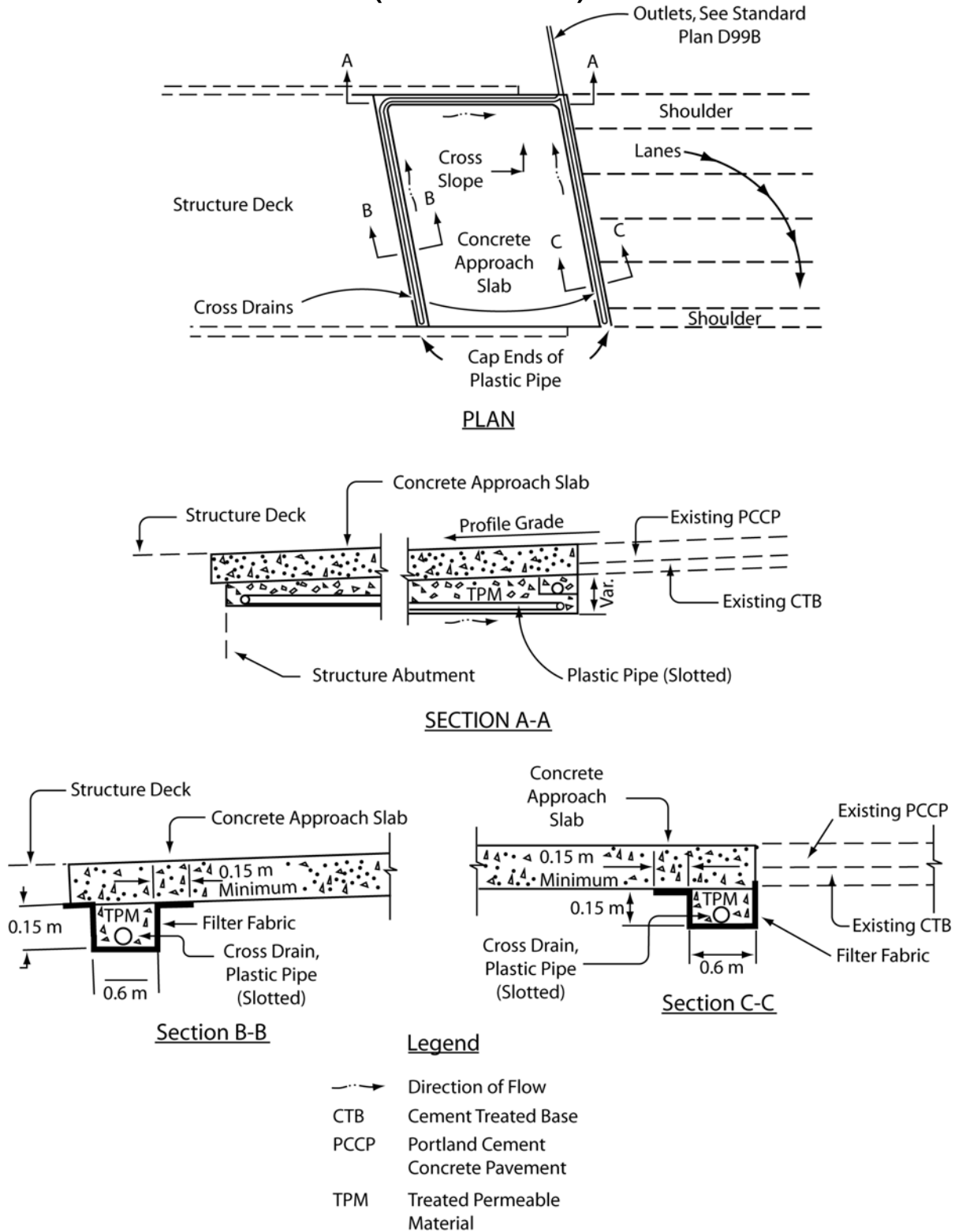
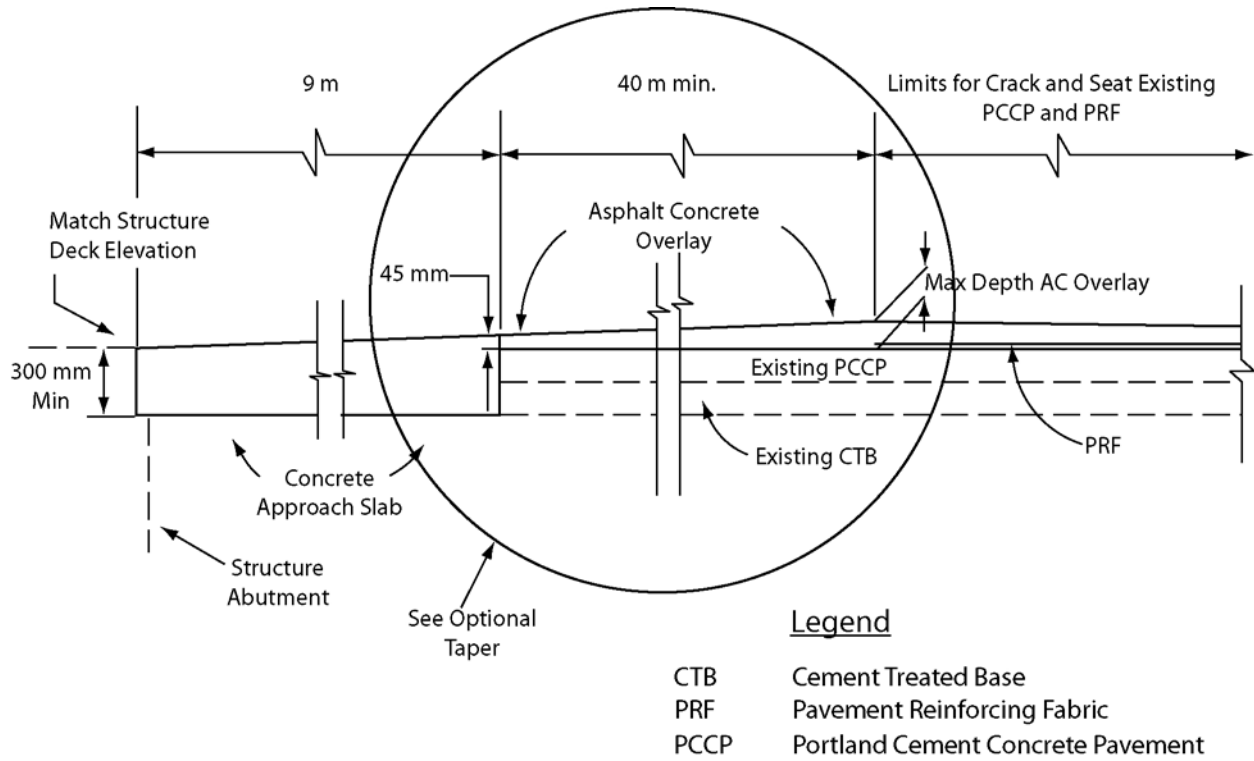
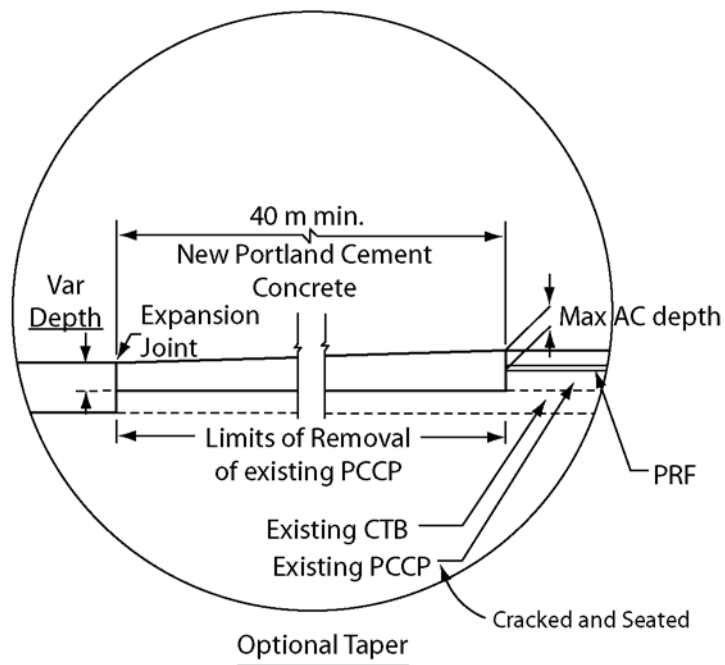

Figure 607.6B
Structure Approach Pavement Transition Details
(Rehabilitation)



Legend

- CTB Cement Treated Base
- PRF Pavement Reinforcing Fabric
- PCCP Portland Cement Concrete Pavement



areas with flat grades to avoid creating a ponding condition at the structure abutment.

Cracking and seating of the existing PCC pavement as well as the pavement reinforcement fabric (PRF) should be terminated at the start of the transition from the maximum AC overlay depth.

AC overlays should not be placed on structure decks without the concurrence of Structures Maintenance Investigations (SMI). The need for overlays on structure decks is the responsibility of the SMI. SMI is responsible for maintaining the structural adequacy of all State bridges. Some reasons for overlays include ride quality and/or deck protection. If an overlay is needed, SMI will provide the recommended strategy. If the recommended strategy is AC or slurry seal, the District will typically provide the details. If another strategy, such as polyester concrete, the details will be provided by either SMI or Office of Structure Design.

- (4) *Composite Pavements.* Flexible surfacing over rigid pavement is considered to be a rigid pavement for structure approach rehabilitation. The guidelines for rigid pavement apply to all composite pavement rehabilitation projects, which include structure approach slab replacements.
- (5) *Traffic Handling.* Traffic handling considerations generally preclude full-width construction procedures. Structure approach rehabilitation is therefore usually done under traffic control conditions, which require partial-width construction.

District Division of Traffic Operations should be consulted for guidance on lane closures and traffic handling.

Pavement joint should not be located underneath the wheel paths.